

**NOTES:**

1. Cylinder stat should be set at 70 C
2. Use screened cables on all sensors (RS No. 368-671)
3. Any sensor cables over 25m increase CSA
4. Some neutrals & earths not shown for clarity
5. All remote electrical equipment shall have correctly rated local isolation
6. When selecting Non Return Valves ensure the closing pressure is less than the minimum power of the pumps.

**IMPORTANT:**  
This drawing to be read in conjunction with the full installation manuals supplied.

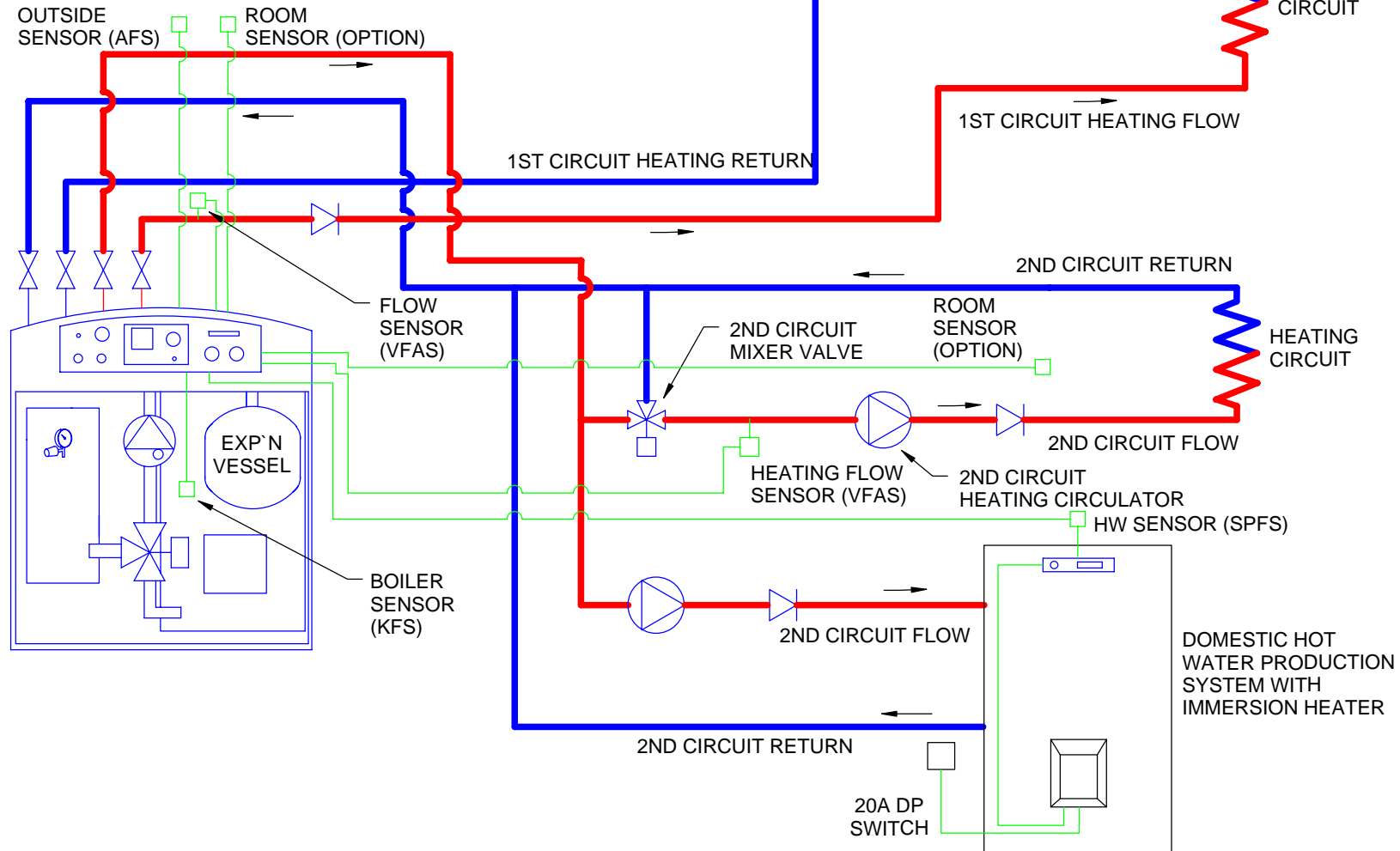

We reserve the right to modify the characteristics of the equipment supplied without notice as part of our continued development of products



**FCX BOILER CONNECTION TO A DOUBLE HEATING CIRCUIT, DOMESTIC HOT WATER PRODUCTION SYSTEM WITH IMMERSION HEATER**

DATE: FEB 03

DRG No FCX Fig 36(i)