

GB
IE

IMPORTANT

FOLLOW COMMISSIONING INSTRUCTIONS
OBSERVE THE WARRANTY CONDITIONS
READ THE WHOLE MANUAL CAREFULLY
NO SAFETY DISCHARGE TO BE REDUCED IN SIZE.
CONDENSE TO BE 32 mm PVC

INSTALLATION

Presentation
Technical specifications
Operation
Installation
Settings of the installation types
Approvals
Warranty



THI 0.9-9 C
THI 2-17 C / THI 5-25 C
THI 5-25 M75 V

GEMINOX

B O I L E R S

High technology heating

**T
E
C
H
N
I
C
A
L

I
N
S
T
R
U
C
T
I
O
N
S**



T30.36290.03

CONTENT

I	- PRESENTATION	4
1	- DESCRIPTION	4
2	- RANGE	4
II	- TECHNICAL SPECIFICATIONS	5
1	- CHARACTERISTICS	5
2	- PIPE CONNECTION DIAMETERS.....	6
3	- DIMENSIONS	7
3.1	- THI 0.9-9 C / THI 2-17 C / THI 5-25 C	7
3.2	- THI 5-25 M75 V	8
4	- LIST OF COMPONENTS.....	9
4.1	- THI 0.9-9 C / THI 2-17 C / THI 5-25 C	9
4.2	- THI 5-25 M75 V	10
4.3	- Control panel	11
5	- MODULATING PUMP CHARACTERISTICS.....	12
5.1	- THI 0.9-9/2-17/5-25 C-M75	12
5.2	- Limitation of over-high outlet temperature:	12
6	- PRESSURE DROP IN THE BOILER (HEATING CIRCUIT).....	13
7	- EXPANSION VESSEL CHARACTERISTICS	13
8	- THERMAL EFFICIENCY	13
9	- DOMESTIC HOT WATER EFFICIENCY	14
III	- OPERATION	15
1	- GENERAL OPERATING PRINCIPLE.....	15
2	- OPERATION OF THE LMU MANAGEMENT UNIT.....	16
2.1	- Normal operating conditions	16
2.2	- Operating diagram	16
2.3	- Principle of air/gas servo-control system	18
2.4	- Air pressure variation procedure	18
2.5	- Emission of pollutants	18
3	- FUNCTIONS COMMON TO THE DIFFERENT VERSIONS	18
3.1	- Anti-freeze function	18
3.2	- Anti-legionella function	18
3.3	- Pump run-on after the end of heating	19
3.4	- Pump kick or selector valve kick	19
3.5	- Boiler overheat protection	19
3.6	- Monitoring of flue gas temperature	19
3.7	- Boiler return temperature control	19
3.8	- Monitoring of hydraulic pressure	19
3.9	- Anti-short burner cycle protection function	19
3.10	- Service function	19
3.11	- Regulator shutdown function	20
3.12	- "Controlled screed drying" function	20
3.13	- LMU programmable key	20
3.14	- LMU Programmable output K2	21
3.15	- Automatic summer/winter switching (only activated with outside sensor)	21
3.16	- Fan drying function	22
4	- DIFFERENT VERSIONS OF THE THI	22
4.1	- THI basic model (without outside sensor, without room sensor)	22
4.2	- THI with outside sensor only	22
4.3	- THI with outside and room sensors	23

IV - INSTALLATION	24
1 - GENERAL.....	24
2 - VENTILATION	25
2.1 - THI models with conventional flue connection	25
3 - POSITION OF THE BOILER	26
3.1 - Rear wall spacer / fitting dimensions	26
4 - DISASSEMBLING THE COVER.....	27
5 - COMBUSTION PRODUCT FLUEING	27
5.1 - Evacuation by chimney flue (B23/C33)	28
5.2 - Adaptor C33	28
5.3 - Balanced flue outlet	31
6 - HYDRAULIC CONNECTION	37
6.1 - Evinox recommendations	37
6.2 - Accessories to connect, install or adjust	37
6.3 - Under-floor heating recommendations	38
6.4 - Heat exchanger flow rate	38
6.5 - Hydraulic connection for models THI 0.9-9 C /THI 2-17 C and THI 5-25 C	39
6.6 - Hydraulic connection for models THI C+ DHW production system of type BS	39
6.7 - Hydraulic connection for models THI 5-25 M75 V	40
7 - GAS CONNECTION	40
7.1 - Connection of a gas safety solenoid	40
8 - ELECTRICAL CONNECTION.....	41
8.1 - Mains connection	41
8.2 - Connection of the sensors to the LMU management unit	41
8.3 - Under-floor heating safety	41
8.4 - Wiring diagram	42
V - SETTINGS OF THE INSTALLATION TYPES	43
1 - SINGLE CIRCUIT	43
2 - DOUBLE CIRCUIT.....	44
2.1 - Without room sensor	45
2.2 - With room sensor	45
VI - APPROVALS	46
1 - DECLARATION OF CONFORMITY	46
VII - EVINOX WARRANTY	47

I - PRESENTATION

1 - DESCRIPTION

Standard description: wall mounted condensing boiler for hot water heating, sealed combustion circuit, pre-mixing burner with air-gas supply, and linear power modulation connecting combustion product types B₂₃, C₁₃, C₃₃, following EN 483 (04/00)

The THI boiler is pre-set in the factory for natural gas H (G20).

This boiler comprises all the necessary accessories for the correct working of a water based central heating circuit specifically:

- one boiler comprising:
 - a high performance double walled condensation exchanger,
- a pre-mixing burner, with stainless steel refractory grate,
- a variable speed 230 Volt fan controlled by the regulator,
- a 230 Volt two way gas valve controlled by the air pressure,
- electronic regulation which ensures power modulation depending on the demands for heating or DHW (LMU control unit),
- a tank to ensure DHW (THI.. M75),
- an outside sensor,
- an expansion vessel,
- a modulating pump PWM signal,
- a 3 bar safety-valve,
- a rear wall spacer,
- Bionibal 0.5 L.

OPTIONAL:

- A rear spacer allowing for the hydraulic connection of the boiler with pipe passage towards the top (THI..C).
- A mounting bracket for light stud wall (THI..M75).
- Horizontal flue kit (C₁₃) allowing the boiler to be connected to a straight horizontal flue + accessories for horizontal connection (extensions, elbows etc.).
- Flue adapter (C₃₃) allowing the boiler to be connected to a vertical flue + accessories for vertical connection (terminal, extensions, elbows etc.).
- Adjustment as a function of the room temperature (REG 73).
- 2nd heating circuit kit allowing the connection of a secondary heating circuit (REG 125).
- 2nd heating circuit clip-in allowing the connection of a secondary heating circuit.
- Clip-in LPB communication kit used for cascade or multi-circuit installations (REG 130).
- Clip-in programmable relay kit allowing a secondary pump to work in parallel (REG 127).
- Gas conversion set allowing the change from natural gas to propane (THI 5-25 C/M75).
- Gas conversion set allowing the change from propane to natural gas (THI 5-25 C/M75).
- Control unit ZHTi 46 (REG 129) controlling an additional heating circuit.
- Control unit ZHTi 47 (REG 128) allowing cascade management for two boilers.
- Solar heating control kit (REG 152).
- DHW sensor kit.
- Selector valve kit for connecting THI..C/BS.
- Domestic hot water production system (type BS).

2 - RANGE

Models	Functions	Combustion products connection
THI 0.9-9 C THI 2-17 C THI 5-25 C	Only heating	Chimney conduit (B ₂₃) Horizontal flue (C ₁₃) Vertical flue (C ₃₃)
THI 5-25 M75 V	Heating and DHW	

II - TECHNICAL SPECIFICATIONS

1 - CHARACTERISTICS

Models		THI			
		0.9-9 C	2-17 C	5-25 C	5-25 M75V
Certification		CE0085AT0244		CE0085AQ0543	
Category / Country of destination: GB/IE		I _{2H}		II _{2H3P}	II _{2H3P}
heat output (Heating)	30/50 °C	kW	1.2/9.8	2,6/18,3	5.4/25.8
	60/80 °C	kW	1.0/9.1	2,3/16,9	4.8/23.9
Heat input (Heating)		kW	1.1/9.3	2,5/17,4	5.0/24.5
Heat input (Domestic hot water)		kW	-	-	-
Efficiency on PCI	30/50 °C	%	109/105.4	108.0/105.8	108.0/105.3
	60/80 °C	%	90.0/97.8	96.0/97.4	96.0/97.4
Efficiency on PCS	30/50 °C	%	98.1/94.9	97.2/95.2	97.2/94.5
	60/80 °C	%	81.0/88.0	86.4/87.7	86.4/87.7
Efficiency according to 92/42 CEE directive (30%) load		%	108.5	108,5	108.5
Specific flow rate (according to EN 625) (DHW)		l/min	-	-	16.0
Useable gases (NG: Natural gas / PG: Propane)			GNH	GNH	GN H - GP
Combustion product temperature	max	°C	80		
Over-heating safety of combustion products		°C	85		
Flow rate of combustion products (0°C, 1013 mbar)	min/max	kg/h	2.0/16.7	4,5/31,3	9.0/44.1
Permitted back pressure (C ₁₃)	max	Pa	100		
Air flow required for combustion (0°C, 1013 mbar)		m ³ /h	11	21	30
NO _x		mg/kWh	class 5 (EN 483)		
CO		mg/kWh	< 50		
Heating service pressure	min/max	bar	1/3		
Domestic hot water service pressure	min/max	bar	-	-	1/7
Heating circuit water temperature	min/max	°C	20/80		
Domestic hot water temperature	min/max	°C	-	-	10/65
Water overheating safety thermostat		°C	100		
Boiler water capacity		liter	2.5	2.5	2.5
heat exchanger capacity		liter	-	-	3.7
Water tank whole capacity		liter	-	-	75
Heatlosses (tank at 65°C)		W	-	-	67
Primary water flow (ΔT 20 K)	60/80 °C	m ³ /h	0.39	0,75	1.03
ΔP water (at nominal flow)		mbar	20	65	130
Thermal losses (ΔT 30 K) (ΔT 50 K)		W W	93 176		
Total capacity of expansion vessel		liter	8	8	8
Useful capacity (with 5m static height)		liter	5	5	5
Acoustic output at minimum heat output 5,1 kW		dB(A)			31,2

Models			THI			
			0.9-9 C	2-17 C	5-25 C	5-25 M75V
Power input (pump at maximum speed)		W	104			
Absorbed electrical power in heating mode :						
Control alone (= Electrical power consumption of the auxiliaries)		W	min. load: 23 max load: 37			
Modulating pump	min	W	30			
	max	W	67			
Stand By Position		W	9.2			
Power supply/frequency			230 V (+ 10% - 15%)/50 Hz			
Class of electrical insulation			1			
Absorbed intensity	max	A	0,45			
Protection factor models B ₂₃ model C ₁₃ /C ₃₃			IP 24 IP 44			
Tare		kg	56	56	56	95,5
Weight packaged		kg	63	63	63	114

2 - PIPE CONNECTION DIAMETERS

Models			THI			
			0.9-9 C	2-17 C	5-25 C	5-25 M75
∅ Combustion products	B ₂₃	mm	125		125	
∅ Combustion products	C ₁₃ C ₃₃	mm	75/110		75/110	
		mm	80/125		80/125	
∅ Gas inlet		inch	1		1	
∅ Heating flow/return		inch	1		1	
∅ D.h.w. inlet/outlet		inch	-	-	-	3/4
∅ Condensation outlet		mm	25		25	
∅ Safety valve outlet		inch	3/4		3/4	
∅ DHW production system connection (option section 13 - page 26 - chapter V - OPTIONS - SERVICING MANUAL) (* 3/4 with coupling)		inch	1*	1*	1*	-

3 - DIMENSIONS

3.1 - THI 0.9-9 C / THI 2-17 C / THI 5-25 C

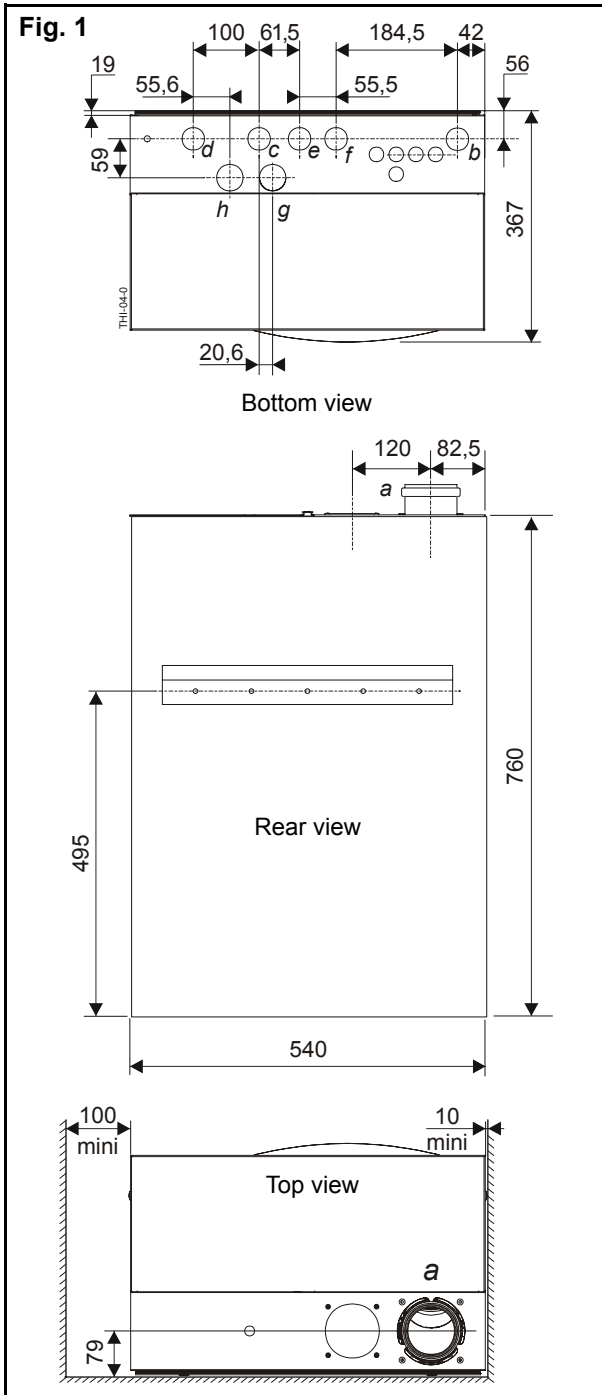

Legend:

- a: Combustion products outlet*
- b: Gas inlet*
- c: Heating flow*
- d: Heating return*
- e: /*
- f: Connection DHW production system (option) (THI C)*
- g: Condensate drain*
- h: Safety valve drain*

3.2 - THI 5-25 M75 V

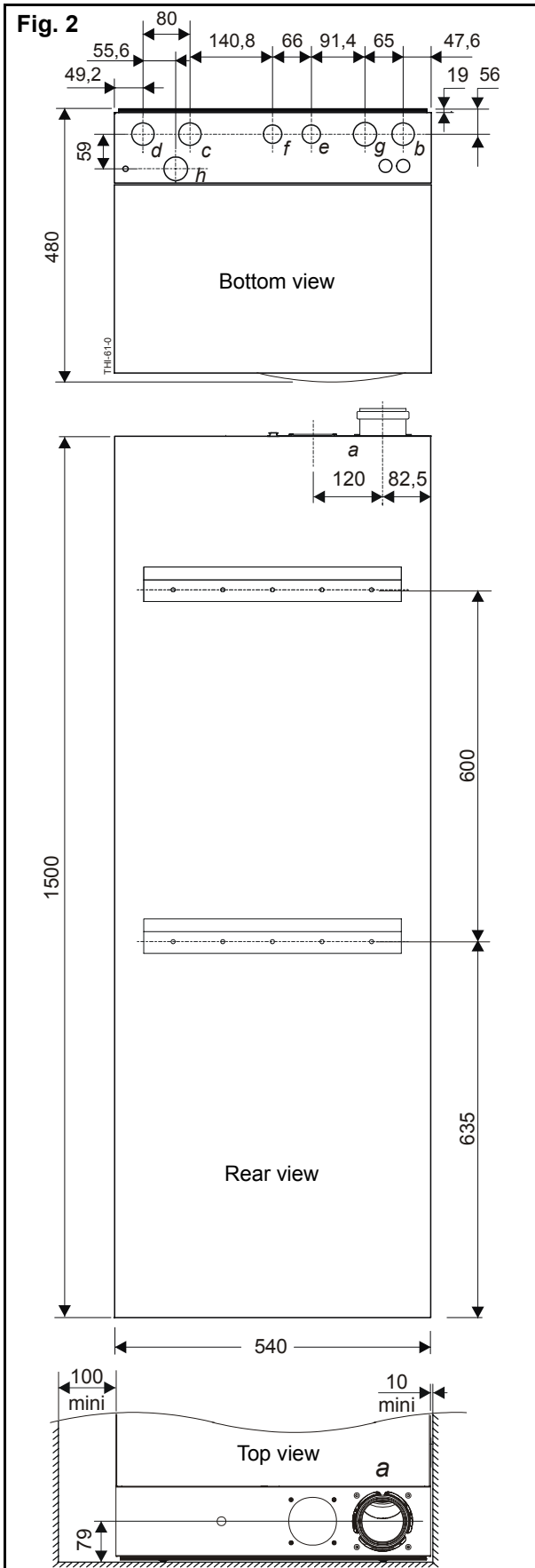

Legend:

- a: Evacuation of combustion products*
- b: Gas inlet*
- c: Heating flow*
- d: Heating return*
- e: Domestic cold water inlet*
- f: Domestic hot water outlet*
- g: Condensate drain*
- h: Safety valve drain*

4 - LIST OF COMPONENTS

4.1 - THI 0.9-9 C / THI 2-17 C / THI 5-25 C

Fig. 3

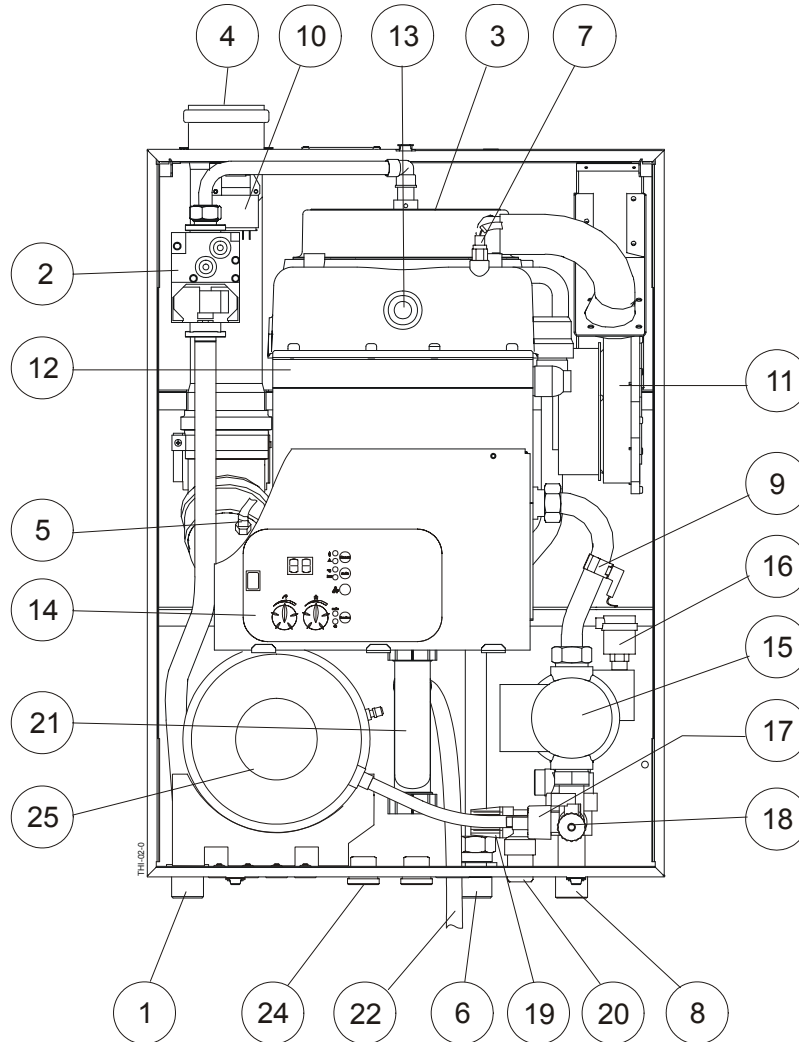

- | | |
|--|--|
| 1) Gas inlet | 15) Pump 230 V |
| 2) Gas valve (solenoids and regulator) 230 V | 16) Air bleed |
| 3) Gas burner | 17) Pressure sensor |
| 4) Combustion products outlet (flue) | 18) Drain tap |
| 5) Flue gas sensor | 19) Safety valve 3 bar |
| 6) Heating flow | 20) Safety valve outlet |
| 7) Heating outlet and safety sensor | 21) Siphon trap |
| 8) Heating return manifold | 22) Condensate drain |
| 9) Boiler return sensor | 23) / |
| 10) Ignition transformer 230 V | 24) Connection for domestic hot water production system (option) |
| 11) Fan 230 V | 25) Expansion vessel |
| 12) Boiler shell | |
| 13) Sight-glass | |
| 14) Microprocessor control panel | |

4.2 - THI 5-25 M75 V

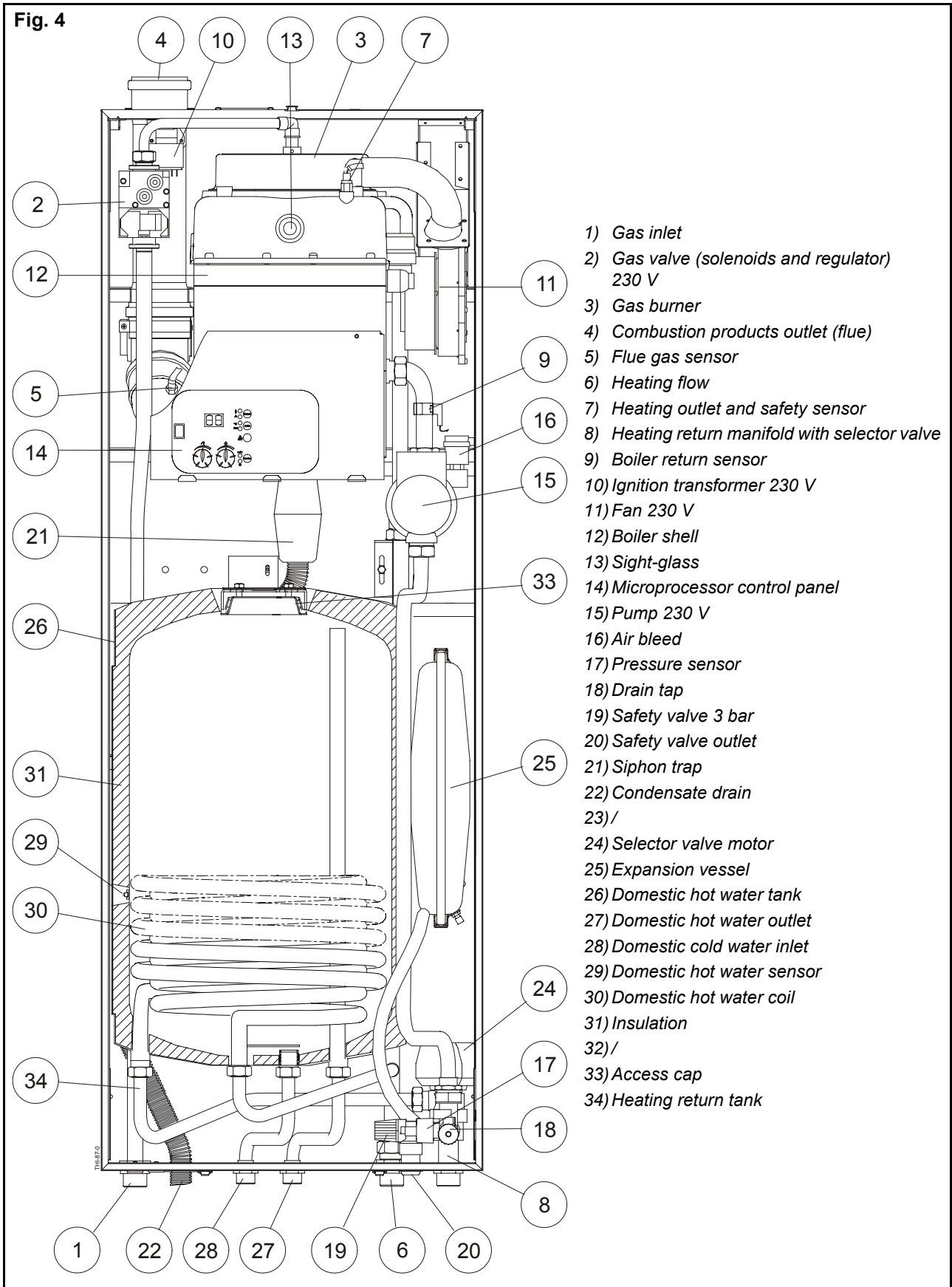

4.3 - Control panel

Fig. 5

1) The "Function" key gives access to 3 operating modes by simply pressing the key:
 auto mode: LED (4) on
 winter mode: LED (5) on
 summer mode: LED (4) and (5) off

2) Regulation of the heating temperature (setting read on the display (13)) *

3) Regulation of the DHW temperature (setting read on the display (13)) *

6) Maintenance key: reserved for servicemen or maintenance (see overleaf)

7) "Info" key gives access to 5 types of information on the display (13) by simply pressing the key:
 Boiler outlet temperature: LED (9) on
 Sensor temperature: LED (9) flashing
 Boiler water pressure: LED (8) on
 Operating phase: LEDs (8/9) off
 Diagnostics: LEDs (8/9) off/
 Display (13) flashing

10) Boiler reset button (After each reset, wait for about 30 seconds before the restart = reset)

11) Alarm: Red LED on

12) Flame indicator: Green LED on

13) Digital display: Alternatively displays the setting selected by the "Info" key and the current default code

14) ON/OFF switch **

* The function of the heating temperature (2) and DHW temperature (3) potentiometers differs according the 3 examples below.

**The On/Off switch (after initial lighting) should be maintained in the "ON" position in order to preserve all the automatic functions of the boiler (anti-freeze, anti-legionella functions, etc).

THI Without room sensor or outside sensor

The heating (2) and hot water (3) temperatures setting are manually set on the boiler control panel.

- The FUNCTION key (1) gives access to 2 operating modes:
 - Auto mode operation (4): no access
 - Winter mode operation: LED (5) on
 - Summer mode operation: LED (5) off

THI Without room sensor and with outside sensor

Possibility of correcting the heating temperature (2) computed automatically using the outside temperature and manual setting of the hot water temperature (3) on the boiler control panel. (section 4.2.2 - page 22 - chapter III - OPERATION - INSTALLATION MANUAL) (The room temperature setting can be changed by + or - 3°C maximum according to the setting).

- The FUNCTION key (1) gives access to 3 operating modes:
 - Auto mode function:
 auto winter = Leds (4) and (5) on
 auto summer = Led (4) on + Led (5) off
 - Winter mode operation: LED (5) on
 - Summer mode operation: LEDs (4) and (5) off

THI With room sensor and outside sensor

Fitting the QAA73 room sensor cancels the functions of the heating temperature setting (2) and hot water setting (3) on the boiler control panel. All the

temperatures required, together with the heating programmes, are set on the QAA 73 (refer to the sensor instructions).

5 - MODULATING PUMP CHARACTERISTICS

Advantages :

- Modulation allows a reduction in the electrical consumption of the pump by adapting its flow to the needs of the installation.
- Varying the flow and controlling the return temperature enables the boiler efficiency to be optimized.
- This modulating pump also reduces the noise created by the installation (circulation noise).



The modulating pump option is only possible with a single heating circuit.

The modulation function can be deactivated via the KonfigRg7 parameter.

It is possible to limit the modulation range via the parameters "NqmodNenn" (Max range) and "NqmodMin" (min. range) (fig. 7 - page 12 - chapter II - TECHNICAL SPECIFICATIONS - INSTALLATION MANUAL).

Action on the "min" allows the equilibrium of the installation to be adapted.

Note:

- A perfectly balanced installation makes for better use of the pump capacities.

5.1 - THI 0.9-9/2-17/5-25 C-M75

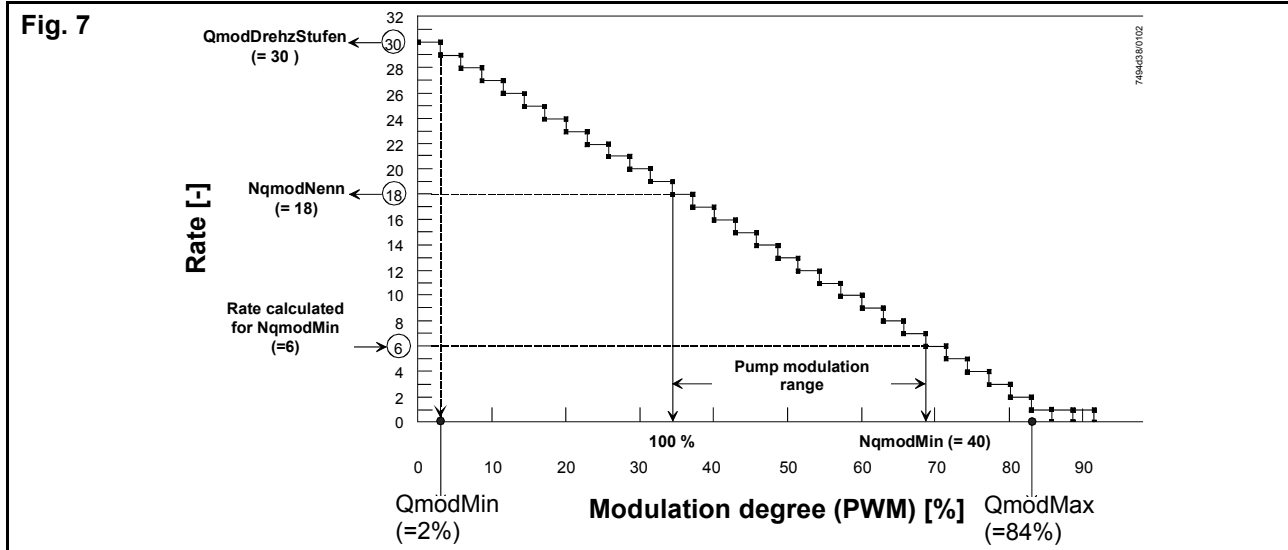
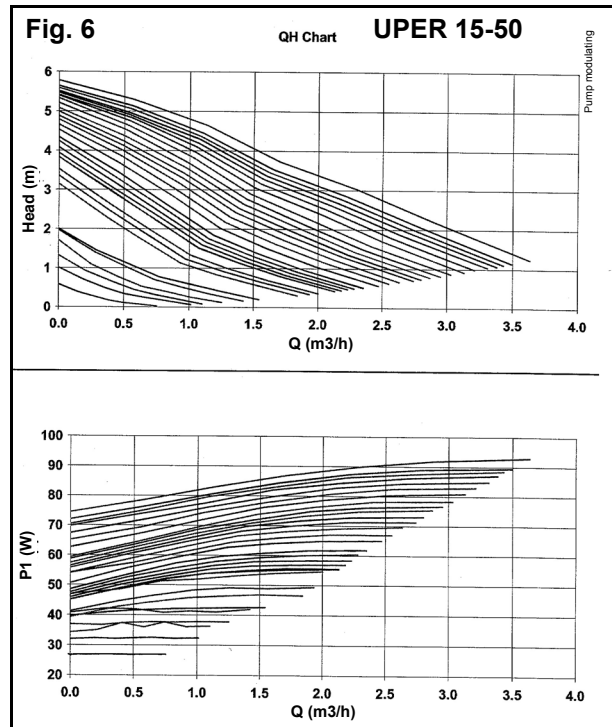

5.2 - Limitation of over-high outlet temperature:

Due to a reduction in pump flow and to obtain the same calorific heat output value, the boiler setup calculates an over-high outlet temperature.

This temperature may be set through a range of 0 to 100% with the "dTUeberhBegr" parameter. (parameter 639 of the QAA 73).

A value of 100% means that the over-high outlet temperature has been totally accounted for.

A value of 0% means that there is no over-high temperature (setting for a non-modulating pump).

The factory setting is 40%.

6 - PRESSURE DROP IN THE BOILER (HEATING CIRCUIT)

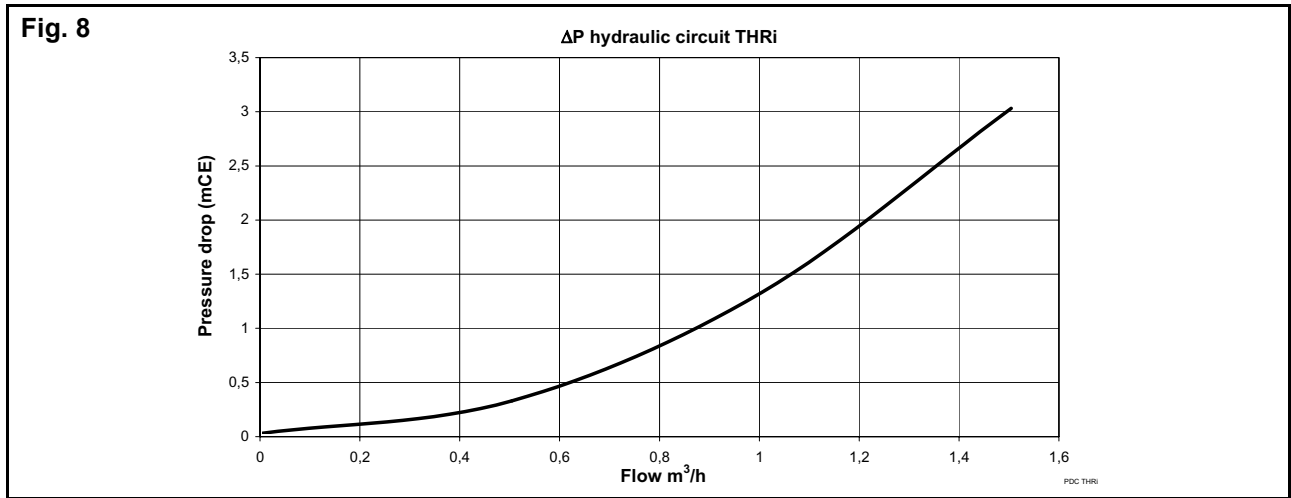

7 - EXPANSION VESSEL CHARACTERISTICS

THI boilers are pre-equipped with an expansion vessel for an installation water capacity of approximately 100 liters.

The expansion vessel absorbs the increase in the water volume in the installation produced by the increase in temperature. The pre-inflation of the vessel sends the internal membrane to the side of the connection and the water dilation pushes on this membrane. Optimum efficiency is obtained when the inflation pressure is equal to the water pressure.

Note:

- The minimum water pressure necessary for the correct working of the installation is defined by the difference in levels between the boiler and the highest point in the installation (e.g. 8 m = 0.8 bar).

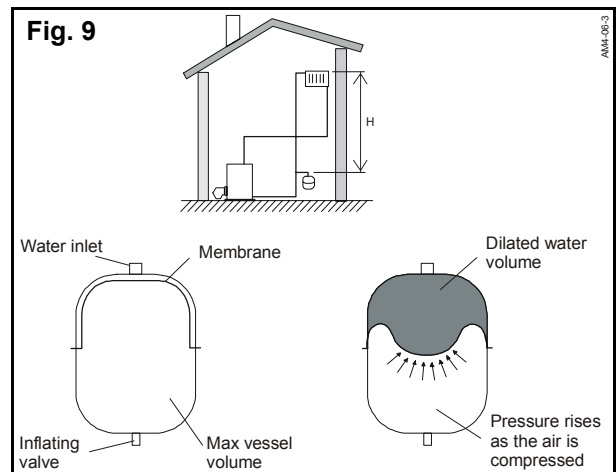

8 - THERMAL EFFICIENCY

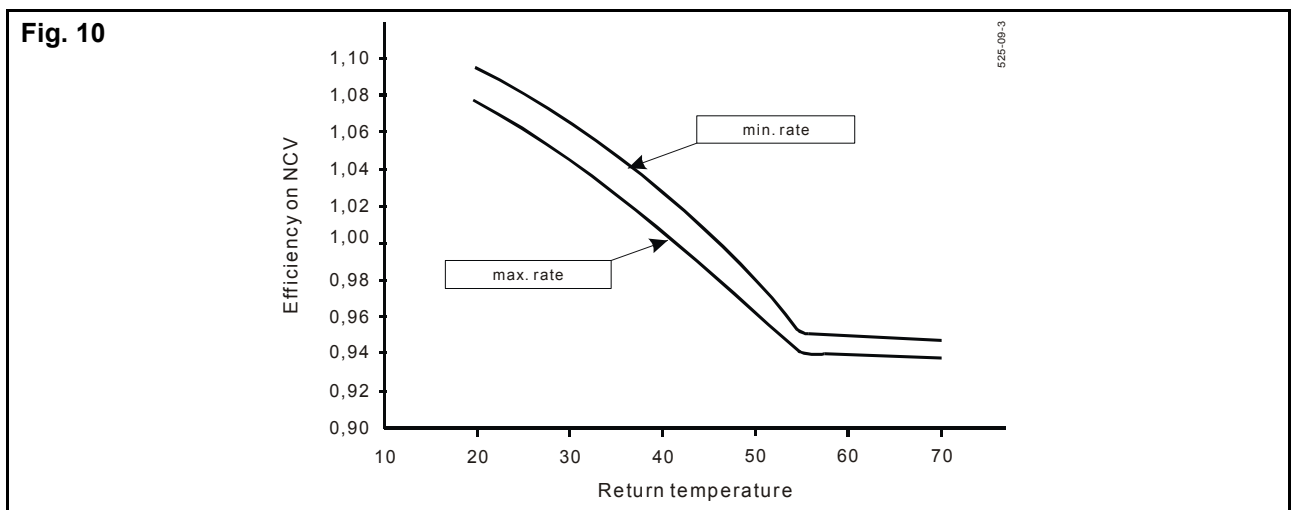

9 - DOMESTIC HOT WATER EFFICIENCY

Models	Heat output at $\Delta T 30 \text{ }^\circ\text{K}$	Continuous flow rate at $40 \text{ }^\circ\text{C}$ (*3)	Specific flow rate (*1)	Pre-heating time at $60 \text{ }^\circ\text{C}$ (*2)	Load time at $60 \text{ }^\circ\text{C}$	Volume drawn at $40 \text{ }^\circ\text{C}$ in 10 minutes	Volume drawn at $40 \text{ }^\circ\text{C}$ in 1 hour
	kW	l/min	l/min	min	min	storage $65 \text{ }^\circ\text{C}$	
						liters	liters
THI 0.9-9 C + BS 100	9,1	4,4	12,3	29	51	160	377
THI 0.9-9 C + BS 150	9,1	4,4	16,3	43	77	241	459
THI 0.9-9 C + BS 200	9,1	4,4	19,9	56	100	313	531
THI 0.9-9 C + BS 300	9,1	4,4	27,8	86	153	476	693
THI 2-17 C + BS 100	16,9	8,09	16	15	28	160	564
THI 2-17 C + BS 150	16,9	8,09	20,2	23	42	241	645
THI 2-17 C + BS 200	16,9	8,09	23,7	30	54	313	717
THI 2-17 C + BS 300	16,9	8,09	31,7	46	82	476	880
THI 5-25 C + BS 100	23,9	11,4	17,6	11	19	176	748
THI 5-25 C + BS 150	23,9	11,4	23,9	17	29	241	813
THI 5-25 C + BS 200	23,9	11,4	27,2	21	38	313	885
THI 5-25 C + BS 300	23,9	11,4	35,2	33	58	476	1047
THI 5-25 M75	23,9	11,4	16,0	8	14	158	729

Cold water temperature = $10 \text{ }^\circ\text{C}$

Storage temperature = $80 \text{ }^\circ\text{C}$

(*1): According EN 625

(*2): Pre-heating time following drawing that corresponds to the specific flow rate.

(*3): Drawing flow rate to be set on the safety control box at start-up (for models [THI M75](#)).

1 - GENERAL OPERATING PRINCIPLE

The THI boiler is a very high efficiency condensing boiler owing to the burner and heat exchanger that benefit from our longstanding experience.

The over-sized fin tube exchanger and its combustion chamber cooled by water in the upper section, combines the functions of heat exchanger and condenser.

Second generation digital control continuously optimizes the operating rate by using information sent to the microprocessor by the sensors fitted on the boiler:

- boiler flow sensor,
- boiler return sensor,
- outside temperature sensor,
- flue gas temperature sensor,
- room sensor,
- pressure sensor,
- fan speed control (pneumatic air/gas control),
- circulating pump speed control,
- communication bus with external regulators.

Each of the sensors is allocated to an algorithm that optimizes the operation and generates information or fault codes that can be read from the display of the control panel or QAA73 [room sensor.i](#)

2 - OPERATION OF THE LMU MANAGEMENT UNIT

2.1 - Normal operating conditions

To access the operating phases of the LMU (display level A4), press the info key (7) three times. The different phases will then be displayed (13).

Note for return to the initial display:

- The phase display will stop automatically after 8 minutes,
- Otherwise, press the info key 2 times more.

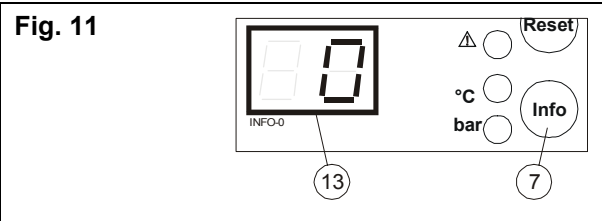

Programming order for normal operating conditions		Programming order for normal operating conditions	
Display	Meaning	Display	Meaning
80	Stand-by (no heating request)	86 87	Ignition - safety time
81	Start-up blocked	10	Heating mode operation
82	Fan speed rise time	11	Hot water mode operation
83	Pre-ventilation time	12	Heating + DHW operation (disabled for THI)
84	Waiting time	20 21	Post-ventilation with last operation command
85	Pre-ignition time	22	Return to initial setting
		99	Fault position (display of current fault code)

2.2 - Operating diagram

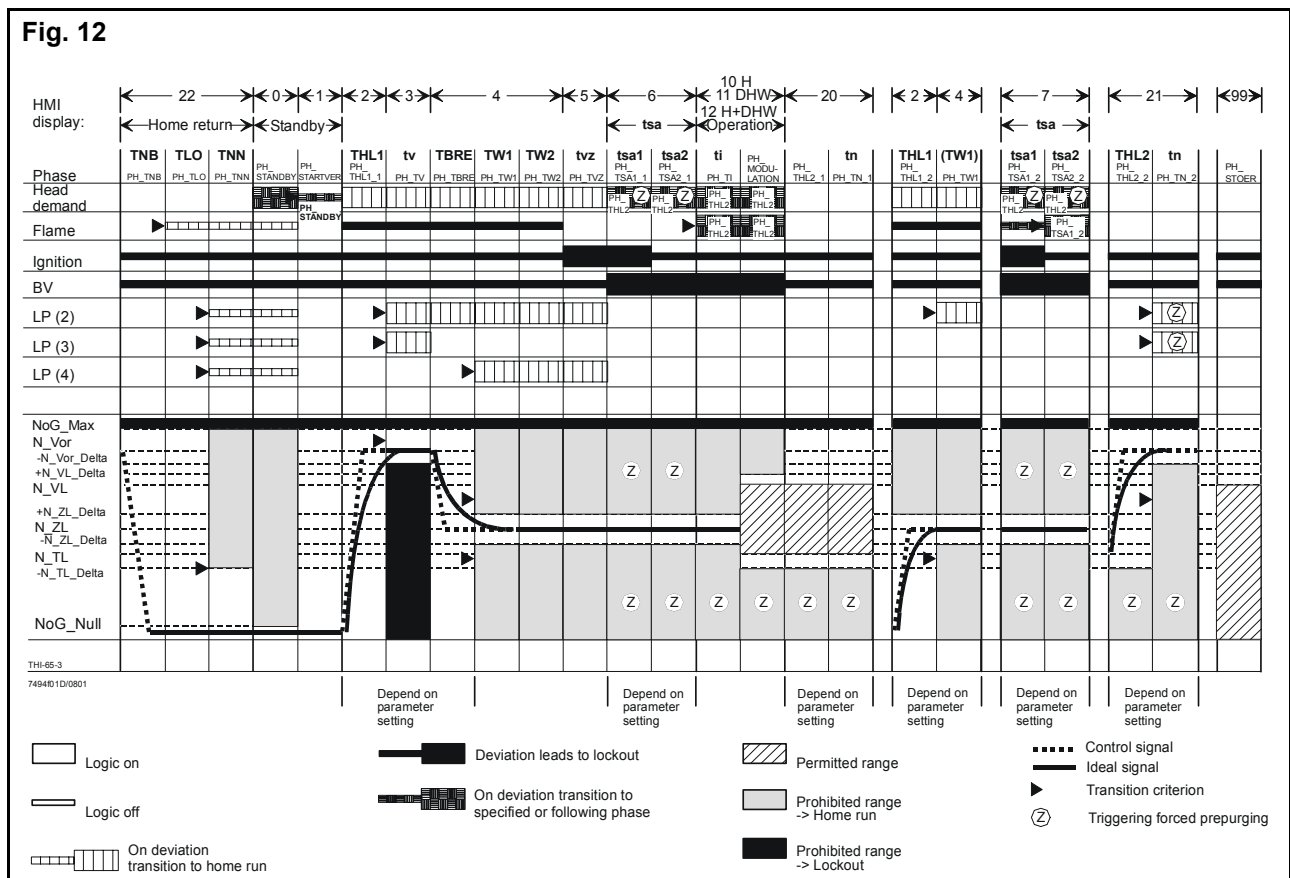

Explanation of the operating phases		
Display	Phase	Description
Veille		
80	PH_STANDBY (unlimited)	The boiler is on standby and waiting for a heating request.
81	PH_STARTVER	Start-up is blocked. The corresponding diagnostic code is emitted (shunt X10-03).
Start-up: heating request		
82	PH_THL1_1 (THL1)	Fan speed rise time: - This time ends as soon as the fan motor speed reaches the program for pre-ventilation
83	PH_TV (tv)	Pre-ventilation time
84	PH_TBRE + PH_TW1	Tapering time - This time ends as soon as the ignition load programmed for pre-ventilation is reached
85	PH_TVZ (tvz)	Pre-ignition time: - Appearance of the ignition arc prior to opening the gas valve, which occurs at the start of phase 6
86 or 87	PH_TSA1_1 + PH_TSA2_1 (tsa)	Safety time - A flame signal should be present before the safety time has elapsed. If this does not occur, another ignition attempt is made.
10 or 11 or 12	PH_TI + PH_MODULATION: • PH_TI.....: • PH_MODULATION.....:	Burner operation 10: heating operation 11: domestic hot water operation 12: heating and domestic hot water operation (disabled for THI) Flame stabilisation interval. In this phase, the LMU (regulator) send its results.
Return to standby: The switch from the operating position to the Standby position is split into "shut-down" and "return to initial setting"		
Shut-down: This occurs when the heating request disappears		
20 or 21	PH_THL2_1 + PH_TN1	Post-ventilation time - The fan remains on during the post-ventilation time
Return to initial setting: Compulsory switch from the shut-down position to standby. This phase is also used to bring the boiler to standby position after exceptional events such as a RESET.		
22	PH_TNB + PH_TLO + PH_TNN:	Return to initial setting

2.3 - Principle of air/gas servo-control system

The gas valve fitted on each boiler is controlled by the air pressure supplied by the fan, thus guaranteeing a correct air-gas ratio over the whole modulation range (constant CO₂). This ratio remains constant despite any pressure drop in the combustion products outlet or the air intake. The air-gas link is pneumatic.

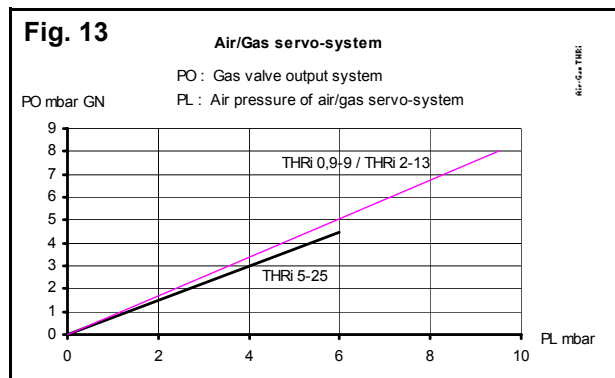

2.4 - Air pressure variation procedure

Linear pressure modulation is carried out by a 230 V variable-speed fan controlled by the LMU which calculates the speed needed at any given time to produce the required pressure.

2.5 - Emission of pollutants

This air/gas control combined with high efficiency pre-mixing burner enables CO and nitrogen oxide (NOx) emissions to be obtained that lie within the values laid down by the most demanding of quality standards.

3 - FUNCTIONS COMMON TO THE DIFFERENT VERSIONS

3.1 - Anti-freeze function

- Boiler anti-freeze protection: When the boiler temperature is below 5°C, the burner and the heating circuit pump are switched on. When the temperature increases and exceeds 15°C, the burner stops and the pump continues to circulate for 10 minutes.
- Anti-freeze protection for the installation: This function uses the real outside temperature. It adopts a different behaviour depending on the temperature. If no measured outside temperature is available, the function is blocked.

Different reactions can occur depending on the outdoor temperature measured:

- If the outdoor temperature is less than or equal to -5°C, the pumps operate continuously,
- If the temperature lies between -4 and 1.5°C, the pumps operate for 10 minutes every 6 hours.
- If the outdoor temperature is over 1.5°C, the pumps shut-down (no heating request).

Any domestic hot water request is given priority.

- Building anti-freeze protection:

The anti-freeze function of the building is a control function (available with the QAA73 room sensor) used to maintain the room temperature at a minimum value, thus preventing the risk of freezing in the building.

3.2 - Anti-legionella function

To provide a substantial degree of protection against the development of pathogenic bacteria in the domestic hot water tank during prolonged shut-downs, the domestic hot water must be heated once a week to a temperature above 60°C.

The anti-legionella function is used for this purpose. It heats the hot water storage tank once a week, on Monday, after the first load, to a 65°C "anti-legionella" temperature.

The function is enabled by default. The setting can be adjusted on line 657 (default value: 65°C). To deactivate the function, all you have to do is set parameter 657 to zero.

After powering up, the anti-legionella function is started after approximately 1 hour. After this first loading of DHW, the anti-legionella function is run every 7 days.

If the anti-legionella setting is not reached after 2 hours maximum, the function is interrupted and restarted the following day.

If the QAA 73 is installed, the parameters of the QAA 73 have priority. By default, the function is activated on the QAA 73 and the anti-legionella setting is 65°C.

3.3 - Pump run-on after the end of heating

When the heating mode ends, the heating circuit pump remains on for 10 minutes..

In hot water storage systems, when domestic hot water heating ends, the heating circuit pump remains on until the boiler temperature drops below 70°C. During this pump run-on period, the selector valve remains in the “domestic hot water feed” position.

3.4 - Pump kick or selector valve kick

If the heating circuit pump has not operated or if the selector valve has not been activated for more than about 24 hours, these elements are activated during operating stops for approximately 5 seconds.

3.5 - Boiler overheat protection

The boiler flow sensor in combination with the heating return sensor provide the overheat safety function.

There are two safety levels:

- if the first temperature value is exceeded, this is signalled by a fault code on the display screen,
 - THI 0.9-9/5-25 : 92°C ,
- if the second temperature value is exceeded (100°C), it is signalled by an alarm code on the display. The boiler switches to safety mode. The boiler must be reset to be restarted.

If the temperature is exceeded, the heat present must be evacuated through the fan and circulation pump.

The two elements (fan and circulation pump) remain on until the boiler shell temperature drops.

In the control algorithm, supervision of the temperature difference ΔT between the flow and return results in the shutdown of the burner if ΔT is above 56°C.

3.6 - Monitoring of flue gas temperature

The monitoring of flue gas temperature is not classed as a function related to safety, but is a priority factor in the control of the boiler.

- The boiler operates at minimum power if the flue gas temperature exceeds 85°C,
- The boiler is on "Stand-by" if the flue gas temperature reaches 88°C.

The boiler can only be restarted automatically after 15 minutes if there is no longer a fault.

3.7 - Boiler return temperature control

The information from the return sensor is used in the event of a very low flow (large ΔT) (reduction in burner power or shut-down of the burner).

It is also used in the control algorithm of the modulating pump (optimization of the boiler thermal efficiency).

It is also enabled for cascade connection.

3.8 - Monitoring of hydraulic pressure

This is a priority function with respect to the control of the boiler.

- the boiler and the pump stop if the pressure is above 4 bar (fault code is displayed).
- the boiler reduces power to 20% if the pressure is between 0.2 and 0.4 bars (fault code is displayed),
- the boiler and the pump stop if the pressure is lower than 0.2 bars (default code is displayed).

3.9 - Anti-short burner cycle protection function

To prevent the boiler from cutting out suddenly, the power failure differential is adjusted according to the real temperature curve of the boiler.

3.10 - Service function

Fig. 14

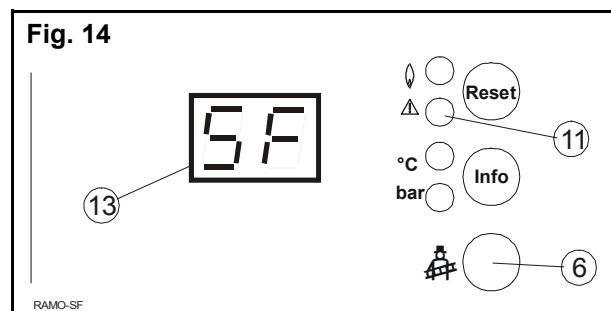

To enable this function, press the service key (6) until the red LED (11) lights up then release it. The LED (11) then starts flashing once per period. The signalling coded “SF” is displayed on the screen (13).



Heating takes place at maximum heat output until arriving at the maximum temperature TKmax.

To stop the service function, press on the service key (6) for 3 seconds then release it.

3.11 - Regulator shutdown function

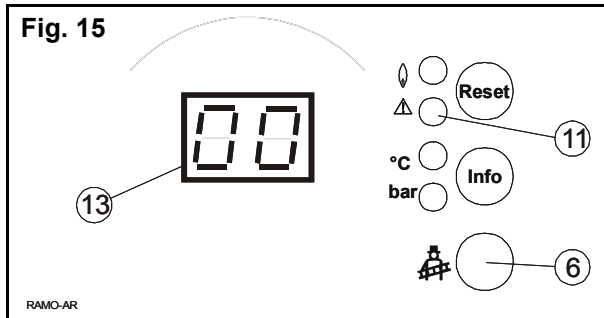
The regulator shut-down function enables the fan motor speed to be set manually via a domestic hot water temperature potentiometer (3), and therefore the heat output of the boiler.



- Press the service key (6) for longer than 8 seconds,
 - The red LED (11) flashes twice per period.
 - The codes   appear on the display (13) and flash twice. This code corresponds to the percentage of the boiler heating rate.

The safety function and the "all or nothing" regulator are operating

To disable the regulator shutdown function, press the service key (6) for 3 seconds then release it.

3.12 - "Controlled screed drying" function

The purpose of the function is the controlled drying of floors designed to receive underfloor heating (during the building phase).

The 'controlled drying' function automatically sets the flow temperature according to a preset temperature profile separate from the outside temperature and the effect of room temperature.

This function can be activated for heating circuits with a pump and/or with a mixing valve, that is for CC1, CC2 or both circuits.

General rule: Although the controlled drying function is already activated for a heating circuit, it can only be run for the second circuit after the first circuit drying operation is ended/interrupted. The times of the two drying functions cannot overlap. The duration of the drying is 10 days per circuit.

The mode on the room unit (QAA73) cannot be switched on the heating circuit(s) when the drying function is activated. For these heating circuits the mode adjusted can only be effective at the end of the controlled drying function.

The controlled drying function is started by the set-

ting of the line 658 or 659 on the QAA73 and can be stopped by resetting these settings.

- If the setting is zero: function deactivated.
- If the setting is one: function activated.

Line 658 lets you manage this function for the **heating circuit with a pump (CC1)**.

Line 659 lets you manage this function for the **heating circuit with a mixing valve (CC2)**.

After a power cut, the function continues from the moment it was interrupted.

The function is signalled by a diode that flashes on the boiler's control panel and by the code 185 on the display.

The regulator shut-down function and the cleaning function are locked if the drying function is activated.

3.13 - LMU programmable key

The following functions can be allocated to the programmable key via the setting KonfigEingang (QAA 73 setting : 614):

- 0: The programmable key function is not used.
- 1: Default, modem function enabled, if the contact (X10-04) is closed; disabled if the contact is open.
- 2: Modem function disabled, if the contact (X10-04) is open; enabled if the contact is closed.
- 3: Hot air curtain function enabled, if the contact (X10-04) is closed.

Hot air curtain function (swimming pool):

This function enables the boiler setting to be raised to its maximum value.

It can be enabled in summer and winter modes.

- Modulation of the burner output is maintained.
- Domestic hot water priority is maintained.
- This function is enabled when the contact is closed.
- There is no effect on the control of a modulating pump.

Modem function:

No QAA 73: Setting 520 of the QAA 73 defines the setting in reduced mode (by default, 6°C lower than the comfort mode setting).

With QAA 73: Setting 6 defines the reduced mode sensor (10°C by default).

In accordance with the wiring diagram of the REG 140, there are two ways of setting the modem function:

Line 614 à 1 – By default, the modem function is enabled, i.e. the boiler is in reduced mode. To set it to normal operation, channel 1 is switched on by a simple telephone call.

Line 614 à 2 – By default, the modem function is disabled, i.e. the boiler is in normal operation mode. To put it in reduced mode, channel 1 is switched on by a simple telephone call. All the other protection functions (boiler anti-freeze, pump kick) remain active.

On the other hand, when this function is activated, some of the other functions are not ensured:

- The antifreeze function of the room temperature is not guaranteed.
- The anti-legionella function of the unit is no longer used.

3.14 - LMU Programmable output K2

The following functions can be transferred to output K2 of the LMU (X2-03) via parameter "KonfigAusgang" (parameter 615 of the QAA 73).

Tension : 230 V + 10 % / - 15%
Intensity : 5mA...1A ; $\cos\phi > 0,8$

- **0 : First heating circuit pump (CC1)** for an installation with a header.
Function valid for :
 - double circuit installations : setting 552 (HydrSystem) of the LMU = 51,
 - SEP double circuit installations : setting 552 (HydrSystem) of the LMU = 55,
 - multicircuit installations : setting 552 (HydrSystem) of the LMU = 67
 - SEP multicircuit installations : setting 552 (HydrSystem) of the LMU = 71.
- **1 : Status output** : If there is a lockout which does not allow the burner control to be started up, the status output will be deactivated.
ex : Control of an additional valve when using liquefied gas.
- **2 : Alarm output** : used to signal a fault in the unit requiring manual unlocking.
- **3 : Operational signal** : signals the operating state of the burner.
- **4** : -
- **5 : Pompe of the second heating circuit,**
- **6 : Domestic hot water circulation pump** :
This function is available with the QAA 73 version 1.4 and above (parameter settings: line 94 of the QAA 73).

- **7 : Output enables when the hot air function is enabled** (Refer to section section 3.13 - page 20 - chapter III - OPERATION - INSTALLATION MANUAL),
- **8 : Hydraulic decoupled pump**: This function controls the pump below the header. It is only available for equipment with one heating circuit (LMU parameter 552 (HydSystem) = 3 or 7) and a flow sensor after the header.



Above version 3.03 of the LMU, this function will no longer be used. It is provided by function 9: System pump Q8.

- **9 : System pump Q8** :

This function controls the network pump. The network pump function must first be enabled via the setting 632 WANfoQ8 (LMU version 3.00 and above).

WANfoQ8 : Heat demand signals to be supported by system pump Q8 :

- **Zone (632.0)**
XXXX XXX0 : zone demand not supported by Q8
XXXX XXX1 : zone demand supported by Q8
- **Heating circuit 2 (632.1)**
XXXX XX0X : heating circuit 2 demand not supported by Q8
XXXX XX1X : heating circuit 2 demand supported by Q8
- **Heating circuit 1 (632.2)**
XXXX X0XX : heating circuit 1 demand not supported by Q8
XXXX X1XX : heating circuit 1 demand supported by Q8
- **DHW (632.3)**
XXXX 0XXX : DHW demand zone demand not supported by Q8
XXXX 1XXX : DHW demand zone demand supported by Q8
- **10 : same as for function 0**
- **11** : -
- **12** : -

3.15 - Automatic summer/winter switching (only activated with outside sensor)

The automatic summer/winter switching function enables summer mode to be switched to winter mode (and vice versa) throughout the year without the need for any intervention.

The heating is shut down (when switching from winter mode to summer mode) when the average outside temperature measured over the preceding 24 hours is over the +1°C setting, namely 20°C.

The heating is also started up again (when switching from summer mode to winter mode) automatically when the average outside temperature measured over the preceding 24 hours is below the -1°C setting, namely 18°C .

- Note:

The switchover setting is set to 19°C and can only be changed by using the QAA 73 room sensor.

The automatic mode must obviously be activated on the boiler as well as on the QAA 73 room sensor for the automatic summer/winter switching to be available.

This function is activated by default in the QAA 73 basic configuration.



If using a QAA 73 to pilot the installation, the same switching temperature should be applied to the QAA 73 (line 46) and the LMU (line 516).

3.16 - Fan drying function

To prevent condensates from accumulating in the fan when there is no negative pressure in the combustion product evacuation conduit (short horizontal flue), it is strongly advisable to activate the drying function.

To activate this function, it is sufficient to set parameter 646 of the QAA 73 to 8.0%.

4 - DIFFERENT VERSIONS OF THE THI



The standard configuration is for the connection of:

- one radiator circuit (CC1),
- one under-floor heating circuit (CC2) via the 2nd circuit clip-in kit.

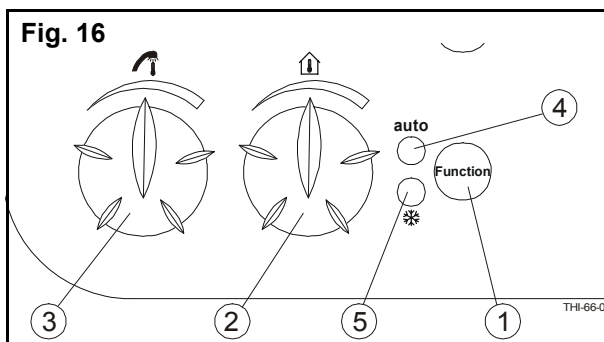

4.1 - THI basic model (without outside sensor, without room sensor)

The heating and domestic hot water flow temperatures are set manually with the respective potentiometers (2 and 3) on the boiler control panel.

The regulator (LMU management unit) thus sets the heating rate required to provide the heating and hot water settings specified by the user.

The "Function" key (1) switches between the summer (hot water only) and winter (heating and hot water) modes. (The auto function is not accessible in this case).

Please refer to section 4.3 - page 11- chapter II - TECHNICAL SPECIFICATIONS - INSTALLATION MANUAL.

Note: The installation of under-floor heating is not possible in this configuration.

4.2 - THI with outside sensor only

4.2.1 - Principle

The domestic hot water temperature is set manually using the potentiometer (3) on the boiler control panel

The heating flow temperature is calculated automatically by the regulator (LMU management unit), and determined according to the outside temperature and the slope of the heating curve. The room temperature can be modified by only $+ \text{ or } - 3^{\circ}\text{C}$ using the heating temperature potentiometer (2).

The "Function" key (1) switches between the summer (hot water only) and winter (heating and hot water) modes.

Refer to section 4.3 - page 11 - chapter II - TECHNICAL SPECIFICATIONS - INSTALLATION MANUAL.

Note:

- An under-floor heating system can be connected by following the instructions in section 4.2.3 - page 23 - chapter III - OPERATION - INSTALLATION MANUAL.

4.2.2 - Modification of the room temperature

The room temperature setting is pre-set to 20°C on the LMU management unit, it can be modified if required:

- Set the heating temperature potentiometer (2) to the required value,
- The display indicates the correction made by $\pm 3^{\circ}\text{C}$ with respect to the 20°C value,

The correction is recognised by the LMU by leaving

the potentiometer on the required position.

4.2.3 - Modification of the heating curve slope

The heating curve slope depends on the characteristics of the building and the size of the heating installation.

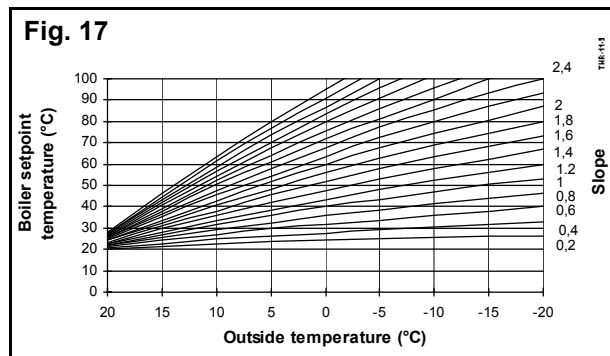

The slope of the heating curve is pre-set in the factory to the value 15 for a radiator system and theoretically gives an room temperature of 20°C for a standard installation.

Note:

- The maximum permitted flow temperature is limited by TKSmax (line 504, via the QAA73 room sensor).

The characteristics of the living area (heating surface, insulation) may require the pre-set values on the LMU to be adjusted.

- For a radiator heating system:
 - Reset the room temperature by +/-3°C (section 4.2.2 - page 22 - chapter III - OPERATION - INSTALLATION MANUAL) then if this correction is not sufficient,
 - Modify the heating curve slope.
- For an under-floor heating system:
 - Reset the value of the heating curve slope of 15 (factory setting) to 8 and according to the installation requirements,
 - Modify the room temperature by +/-3°C (section 4.2.2 - page 22 - chapter III - OPERATION - INSTALLATION MANUAL).

4.3 - THI with outside and room sensors

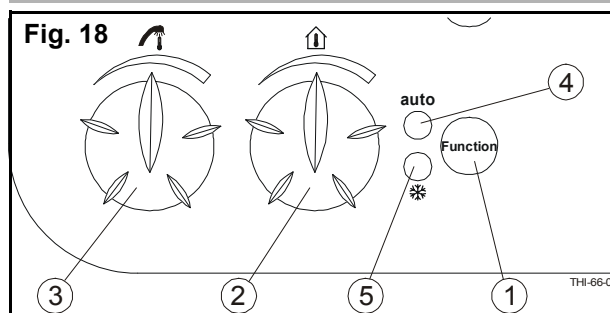

Installing the QAA73 room sensor on the boiler cancels the functions of the setting potentiometers of the heating (1) and domestic hot water (2) temperatures on the boiler control panel. All the temperatures, the operating settings and the heating programmes are set on the QAA 73 (please refer to the instructions supplies with the sensor).

Note:

- For heating by radiators or by under-floor heating, refer to section 4.2.3 - page 23 - chapter III - OPERATION - INSTALLATION MANUAL.

4.3.1 - Automatic summer/winter switching

Refer to section 3.15 - page 21 - chapter III - OPERATION - INSTALLATION MANUAL.

4.3.2 - Room temperature compensation function

This function corrects the boiler flow temperature according to the real room temperature measured by the QAA 73 room sensor.

The QAA 73 can be deactivated or configured differently according to the wishes of the customer (refer to heating engineer setting line 75).

Note:

- The "room temperature compensation" function is activated by default on the CC1 heating circuit - standard configuration of the sensor.
- The function is activated if the room sensor is placed in a room whose temperature is typical of the accommodation. This room must not be fitted with temperature control radiators. The room sensor must be fitted away from sources of heat or cold.

When the room temperature compensation is inactive, the QAA 73 room sensor becomes a remote control device acting on the heating curve for the day-night temperature drops.

4.3.3 - Auto-adapt function

This function automatically corrects the heating curve by measuring the real room temperature.

The auto-adapt function is deactivated in the basic configuration. It can be activated via line 77 by using the +/- keys.



When the auto-adapt function is activated, the room temperature compensation function must also be activated, section 4.3.2 - page 23 - chapter III - OPERATION - INSTALLATION MANUAL.

IV - INSTALLATION

1 - GENERAL

Installing a wall-mounted gas boiler presents no particular difficulty.

The installation of the boiler must be carried out by a competent person in accordance with the relevant requirements of the Gas Safety (Installation and Use) Regulations, Building Regulations, Model Water Byelaws and the Building Standards (Scotland) Regulations. It must also comply with the current I.E.E. Wiring Regulations and the relevant recommendations of the following British Standard Codes.

Regulations and the relevant recommendations of the following British Standard Codes of Practice.

- CR331.3 Low pressure installation pipes.
- BS.5449.1 Forced circulation hot water systems.
- BS.5546 Installation of gas hot water supplies for domestic purposes.
- BS.5440.1 Flues (for gas appliances of rated input not exceeding 60 kW).
- BS.5440.2 Air supply (for gas appliances of rated input not exceeding 60 kW).
- BS.6798 Boilers of rated input not exceeding 60 kW.

Note:

- The boiler is only suitable for installation in a sealed system and must not be used with an open vented system.

LOCATION OF BOILER

The boiler can be installed on the inner face of an external wall - and some internal walls - providing they are flat, vertical and capable of adequately supporting the weight of the boiler and any ancillary equipment.

The boiler may be installed in any room or internal space, although particular attention is drawn to the requirements of the current I.E.E. Wiring Regulations and, in Scotland, the electrical provisions of the Building Regulations applicable in Scotland with respect to the installation of the boiler in a room or internal space containing a bath or shower. Where installation is in a room containing a bath or shower, any electrical switch or boiler control utilising mains electricity should be situated so that it cannot be touched by a person using the bath or shower.

Where installation will be in an unusual location, special procedures may be necessary and BS.6798 gives detailed guidance on this subject.

A compartment used to enclose the boiler **MUST** be designed and constructed specially for this purpose.

An existing cupboard or compartment may be used provided it is modified for the purpose. Details of essential features of cupboard/compartment design, including airing cupboard installations, are given in BS.6798.

In siting the boiler, the following limitations **MUST** be observed:

- 1) *The position selected for installation **MUST** allow adequate space for servicing in front of the boiler and for air circulation around the boiler.*
- 2) *This position **MUST** also permit the provision of a satisfactory balanced flue termination.*

Note:

- If the boiler is to be fitted in a timber framed building, it should be fitted in accordance with the British Gas publication "Guide for Gas Installations in Timber Frame Housing". Reference DM2. If in doubt, advice must be sought from the Local Gas Region of British Gas.

When siting the boiler, provision must be made for the disposal of the condensate, see Section 4 -Condensate drain.

The pressure relief valve connection should be routed to an external, visible point where the discharge of steam or water cannot create a hazard to persons or property. BS.5449: 1 refers.

GAS SUPPLY

Installation pipes should be fitted in accordance with CP.331.3.

The complete installation must be tested for soundness and purged in accordance with CR331.3.

FLUEING

Detailed recommendations for flueing are given in BS.5440.1. The following notes are intended for general guidance.

AIR SUPPLY

a) - For room-sealed systems

Detailed recommendations for air supply are given in BS.5440.2. The following notes are intended for general guidance.

Where the boiler is to be installed in a room or internal space, the boiler does not require the room or internal space containing it to have a permanent air vent.

b) - For natural draught system:

Detailed requirements are given in BS 5440.2

WATER CIRCULATION SYSTEM

The expansion vessel is suitable for systems up to **100 litres** water content. For systems in excess of this capacity an additional pressurised expansion vessel will be required. BS7074 and "British Gas Specifications for Domestic Wet Central Heating Systems' Part 3 gives guidance in this subject.

The central heating system should be in accordance with the relevant recommendations given in BS.6798 and, in addition, for small bore and micro-

bore systems - BS.5449.1. The domestic hot water system, if applicable, should be in accordance with the relevant recommendations of BS.5546.

Copper tubing, to BS. 287 1. 1, is recommended for water carrying pipework.

ELECTRICAL SUPPLY

- Wiring external to the boiler must be in accordance with the I.E.E. Wiring Regulations and any local regulations.

2 - VENTILATION

2.1 - THI models with conventional flue connection

- All fuel burning devices consume a quantity of air that is proportional to their power. Efficient ventilation of the installation's premises is therefore necessary (according to installation standards).
 - High ventilation, with a free section of at least 100 cm², should be placed at least 1.80 m above the ground, as well as an air inlet, in the lower part, of a cross-section of 100 cm².
- To avoid any form of corrosion, the combustion air must be free of any harmful agents. They are thought to encourage the corrosion of halogenated hydrocarbons, containing combinations of chlorine or fluorine, which can be found in solvents, paints, glues, gas propellants and domestic cleaning products, etc.

3 - POSITION OF THE BOILER

Define the location of the boiler by taking into account various conditions: environment, accesses to the boiler, etc.

3.1 - Rear wall spacer / fitting dimensions

Fig. 19

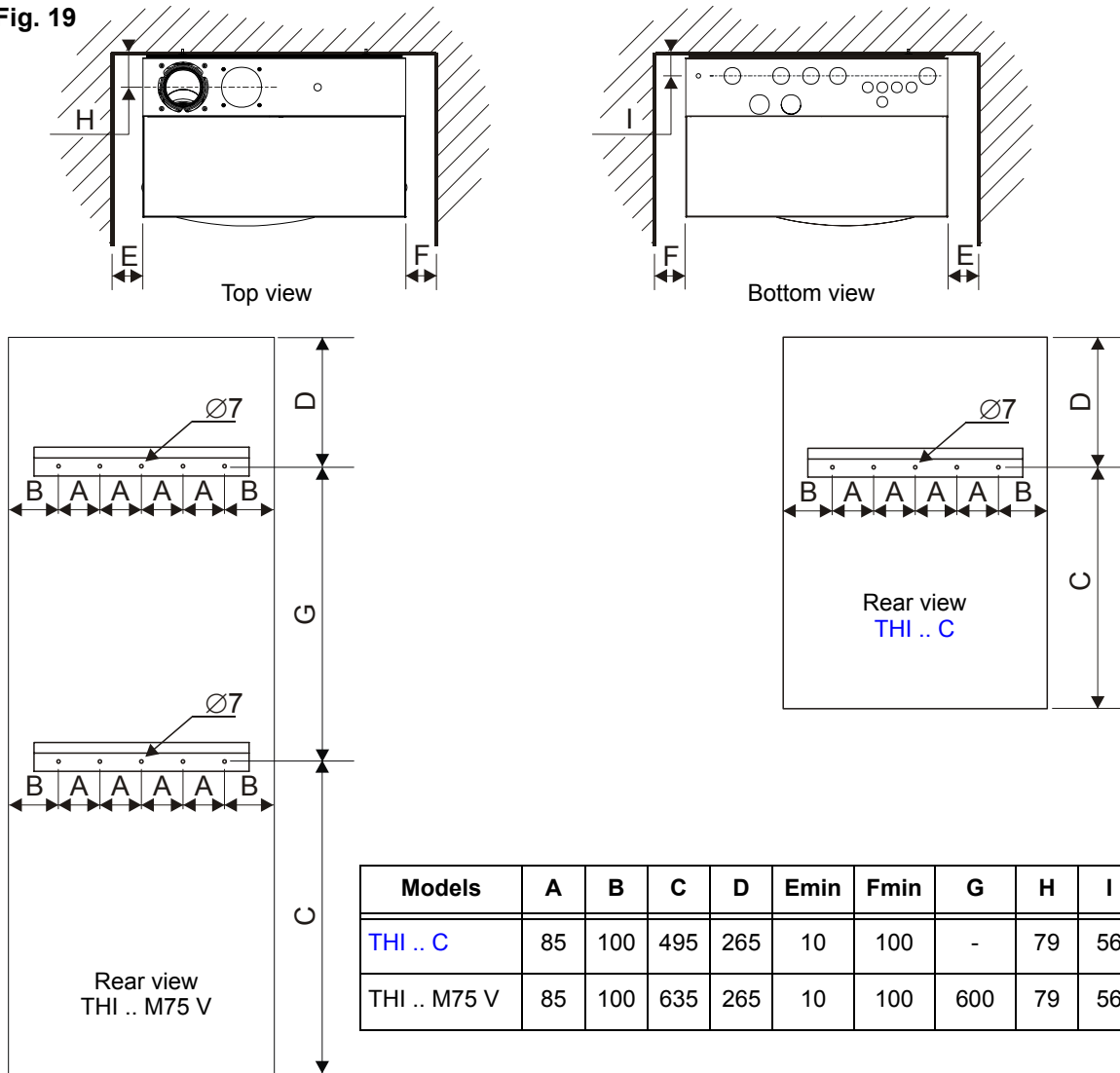

For the vertical balance flue versions:



In order to distribute the load evenly, the boiler is delivered with two support brackets:

- Ensure that they both have the same centre distance when drilling the holes,
- Also ensure that they are in the same plane. If the wall is not flat, fit an intermediate metal support.

4 - DISASSEMBLING THE COVER

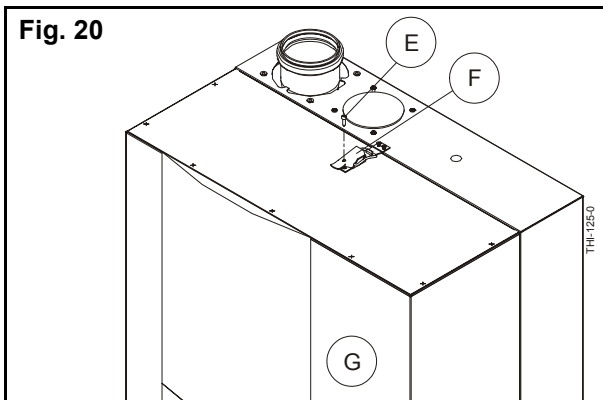

To open the front panel of the boiler:

- loosen the 2 screws (E) on each latch (F) (one above the cover and one below),
- unlock the 2 latches (F),
- open the front panel (G) of the boiler.

5 - COMBUSTION PRODUCT FLUEING



The combustion product outlet systems described in this manual are systems normally used on the European market. However, some of them cannot be used in all the countries of the EEC. The installer or client must ensure that the flue system chosen complies with local installation regulations.

Please note that these are only samples of our standard flue configurations. For flue lengths in excess of the standard lengths shown please see our website at www.evinox.co.uk <[http:// www.evinox.co.uk](http://www.evinox.co.uk)> for details of our other flue systems including the twin pipe flue system, chimney liner systems, and our horizontal and vertical cascade systems. Or contact our technical department for design of special applications.

For the installation of the combustion product evacuation system, C13/C33 accessories supplied as an option or an authorized B₂₃/C₃₃ type combustion product system must be used.

The optional polypropylene combustion product evacuation tubes are exclusively reserved for assembly with a condensation boiler, maximum temperature 120 °C. The combustion products of the unit are evacuated at low temperature (50 to 100°C) and saturated in humidity.

The material for the lining must be chosen specifically for “the condensation burner boiler” and be corrosion proof.



The suitable materials certified as combustion product systems are:

- 316 L stainless steel,
- PP, PPTI polypropylene,
- PVDF

Refer **imperatively** to the CSTB technical notice or to the **technical documentation of application (DTA)** for fitting flues.

Irrespective of the connection type B₂₃/C₁₃/C₃₃:

- To avoid accidental dislocation:

- Check that the air inlet and combustion product extraction outlet tube and bend joints are properly sealed after mounting.
- **Ensure that sealing joints have been fitted.**
- Use fastening collars (**supplied as an option**) or clamps to solidly secure **to the wall the elements of the flue - at least one collar clamp per female fitting of each flue element.**
- To make assembly easier, apply our lubricant over 5 cm of the section of the tube to be fitted.
- All vertical flues to be supported every 2m or otherwise instructed for special applications.
- All horizontal flues to be supported every 1m.
- The tubing connections are arranged so that no condensate is retained and to ensure that they are transferred up to evacuation (descending slope of 3% between the base of the flue and the boiler).

5.1 - Evacuation by chimney flue (B₂₃/C₃₃)



An existing chimney flue can be used provided that it is cleaned before the lining is fitted.

It is advisable to connect the boiler to the vertical flue by means of a condensate evacuation T-bracket to prevent too large a volume of condensates being transferred by the boiler.

Only the 1 adapter specified below is supplied as options by Evinox. Please contact your distributor for the supply of other parts of the combustion product evacuation systems.

5.1.1 - Accessories

- order separately -

5.2 - Adaptor C₃₃

Adaptor used to connect a Ø 80/125 sealed connection of type C₃₃.

See kit assembly guide for the part.

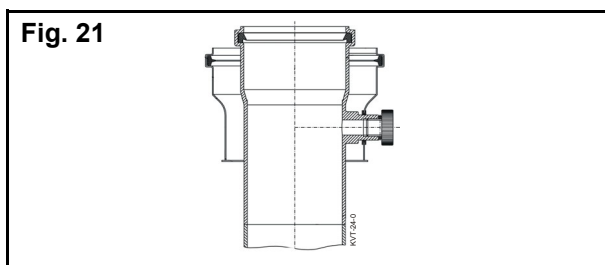

Reference	O10.33702
-----------	-----------

5.2.1 - Standard natural draft configuration (B₂₃) (flue operating at negative pressure)

Definition: Lining of an existing chimney flue by a sealed **STAINLESS STEEL** corrugated flue of Ø 125.

- The termination is specific to this configuration and the outlet must be **above** the roof (comply with the specification of the decree of 22 October 1969),
- **Do not use the hose for a horizontal assembly: condensate may be retained.**
- Fit a siphon (4) with a minimum 50 mm seal between the bleed T-bracket and the waste water pipe,
- **Ventilation for the flue (8) and the heating system (section 2 - page 25 - chapter IV - INSTALLATION) must be provided.**
- If the boiler is installed in premises that have mechanical air extraction, ensure that this does not cause negative pressure.
- The premises must never be fitted with other appliances using natural draft to operate.
- The air is sucked in by the burner directly from the room in which the boiler is fitted.

5.2.1.1 - Installation example (B₂₃)

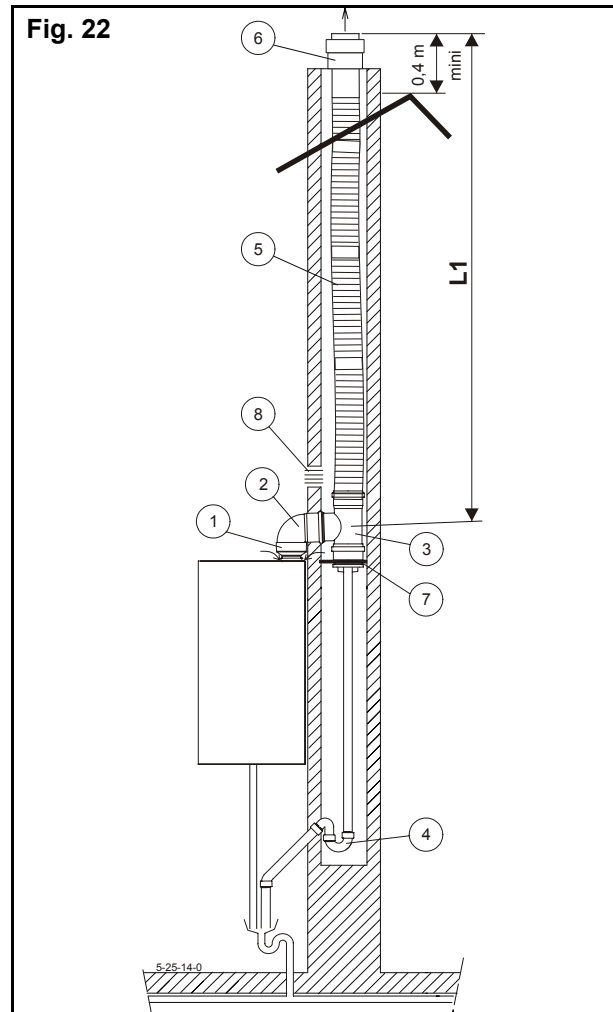

Accessories:

- 1) Sealed flue adaptor Ø 75/125,
- 2) STAINLESS STEEL sealed 90° elbow Ø 125*,
- 3) STAINLESS STEEL bleed T-bracket Ø 125*,
- 4) Siphon*,
- 5) STAINLESS STEEL corrugated flue of grade 316 L, Ø 125 (according to installation standards),
- 6) Termination (above the roof) (according to installation standards),
- 7) Bleed T-bracket support
- 8) Lining ventilation (according to installation standards),

* accessories not supplied

L1max (according to installation standards),

5.2.2 - Sealed configuration (C₃₃)

Definition: Lining of an existing chimney flue, sealed with respect to the installation room by a PP corrugated flue of Ø 80 (in this case the air inlet is obtained by the chimney flue around the combustion product outlet Ø 80) - (no ventilation constraints for the boiler).

- The roof termination specific to this configuration can have an outlet **below** the roof,
- **Do not use the hose for a horizontal assembly: condensate may be retained.**
- Fit a siphon (5) with a minimum 50 mm seal between the bleed T-bracket and the waste water pipe,
- The bleed T-bracket at the foot of the flue is optional when the vertical flue is short ($L1 < 5$ m),
- The air is sucked in by the burner from outside the room through the concentric terminal,
- **Refer to the CSTB technical notice for installing flues.**

5.2.2.1 - Installation example (C₃₃) in a chimney

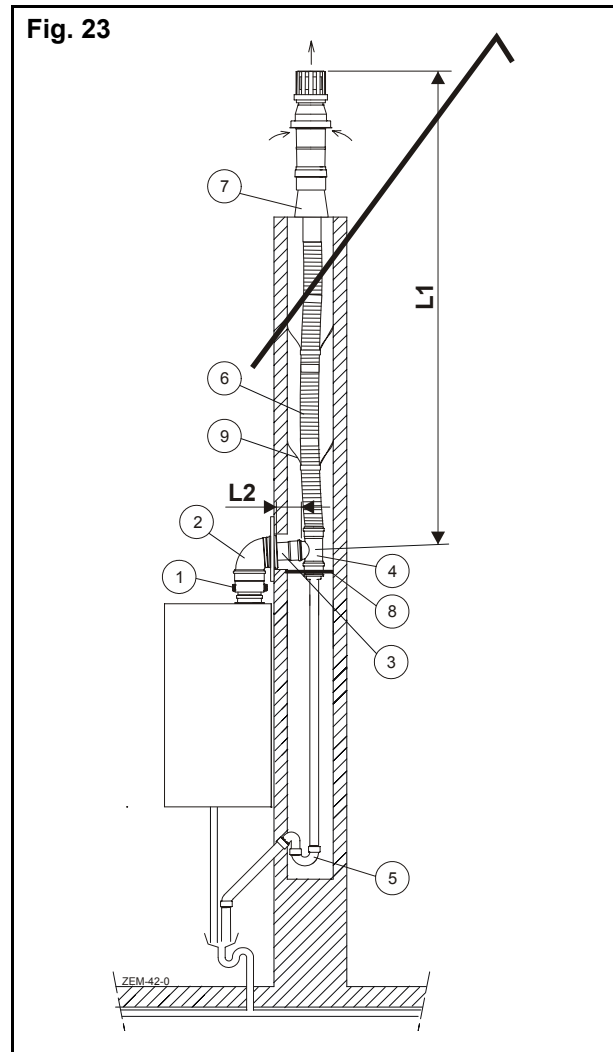

Accessories:

- 1) PP vertical flue adaptor Ø 80/125,
- 2) 90° concentric elbow Ø 80/125*
- 3) PPtl tube Ø 80 (cut to the length required)*,
- 4) Bleed T-bracket PPtl Ø 80 (preferably to be used) or Ø 80 with 90° elbow*,
- 5) Siphon*,
- 6) PP corrugated flue Ø 80*,
- 7) Termination (outlet possible below the roof)*,
- 8) Bleed T-bracket support*,
- 9) Chimney spacers*.

* accessories not supplied

Maximum length allowed:

$$L_{max} \leq 1 \text{ m} + L2 + 1 \text{ m} + L1 \leq 14 \text{ m}$$

Each 90° elbow or T-bracket added reduces the total length allowed by 1 m.

5.3 - Balanced flue outlet

5.3.1 - Balanced flue system installation requirements:

The three statutory clearance distances according to the installation standards are:

- **A = 0.40 m:** minimum clearance distance of the combustion production extraction outlet axis to any opening or of the ventilation outlet,
- **B = 0.60 m:** minimum distance from the axis of the combustion production extraction outlet to any other ventilation air inlet,
Two balanced flue terminals from two separate boilers, positioned side by side, must be separated by a minimum distance of 0.6 metres.
- **C = 1.80 m:** combustion product extraction outlet and air inlet of sealed circuit units with openings at less than 1.80m from the ground must be efficiently tamper-proof so as to prevent any intervention that could affect correct functioning.

Combustion product extraction outlets that open out directly onto an outside route (public or private road) less than 1.80m from the ground, except for condensation installations, must have a fixed deflector that redirects discharged gas more or less parallel to the wall.

Recommended distances:

- **D / F = 0.30 m:** centre distance from the combustion product extraction outlet to the ground, from a roof overhanging or above a balcony,
space between the combustion product extraction outlet and a gutter or drainpipe.
- **E = 2.00 m:** distance of a combustion product extraction outlet from a hedge, plant, boundary or fence,
Please refer to current CORGI legislation regarding fences, boundaries and the need to take into consideration the possibility of a future building on the boundary. In all cases you should assume that a future building can be built up to the boundary or fence.

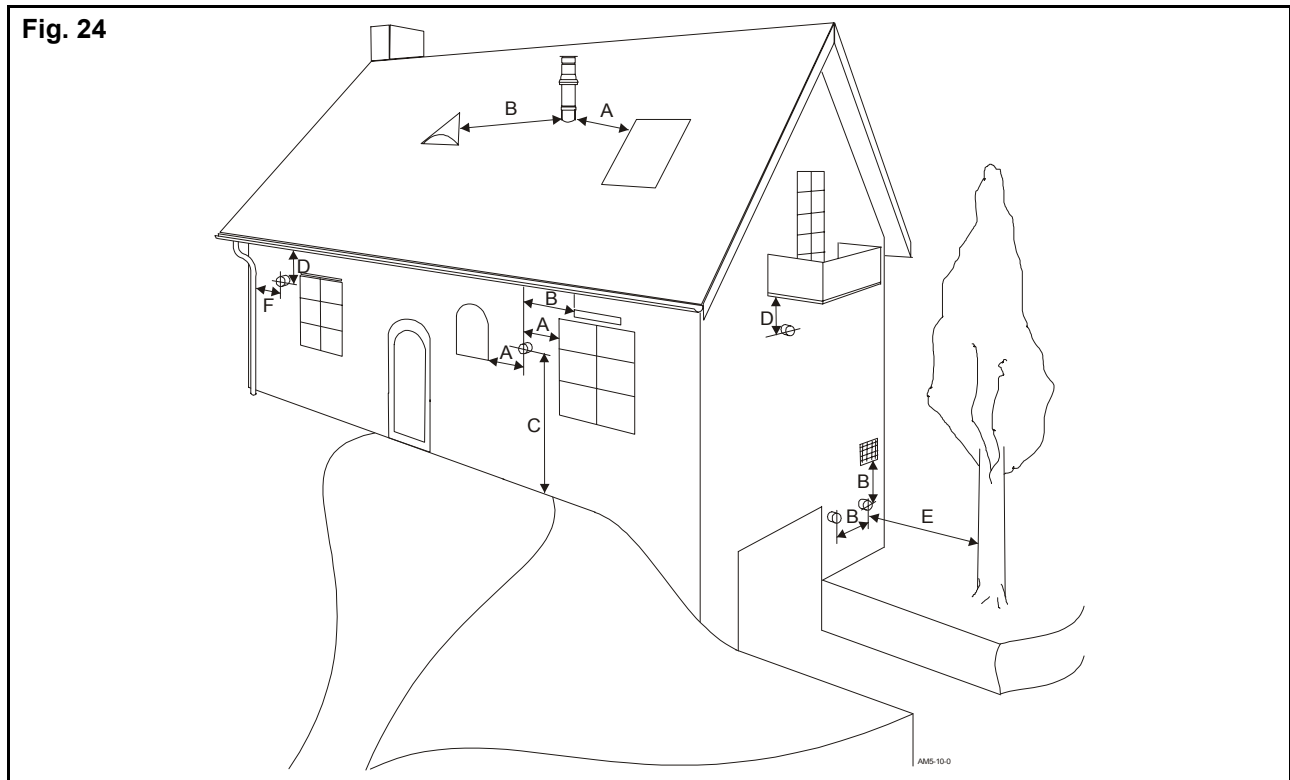



Air intake by the burner and extraction of combustion product is carried outside the premises by using concentric tubes.

5.3.2 - Drainage by horizontal balanced flue (C₁₃)

Evinox recommendations



Horizontal balanced flue installation is possible when the wall next to the boiler leads to a well-ventilated area on the outside.

Do not place the flue terminal :

- within 2m of a ventilation outlet or opening window
- at the front of the building or in an access area (possible obstruction). combustion products odour, presence of a cloud of vapour of a size that will vary in accordance with the weather conditions.
- within 2 m of the ground or directly accessible to a small child (risk of obstruction, the chimney terminal can be protected with a protection device - not supplied).

The horizontal balanced flue kit can be fitted to the right or lefthand side or directly to the rear of the boiler and can cross a wall-thickness of 1 metre maximum.

When installing the horizontal balanced flue, use a 2% upward grade towards the outside for the combustion product tube.

- Standard balanced flue length: L = 1 m
- Maximum linear length of horizontal flue: Lmax = 4 m

5.3.2.1 - 1 m horizontal balanced flue kit (option)

See kit assembly guide

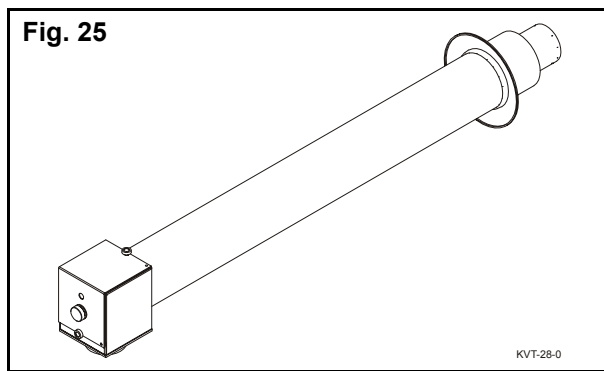

Reference	Length (mm)
V00.15225	1000

5.3.2.2 - 1 m polypropylene concentric flue extensions (option)

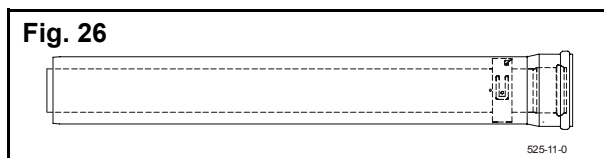

Reference	Length (mm)	Ø int. (mm)	Ø ext. (mm)
V00.17572	1000	75	110

5.3.2.3 - Polypropylene concentric bends (option)

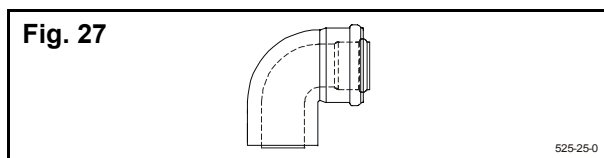

Reference	Bend type	Ø int. mm	Ø ext. mm
V00.17573	90°	75	110

Note:

- Each 90° bend added reduces the total authorised length by 1 m

5.3.2.4 - Adapting collar for the horizontal balanced flue

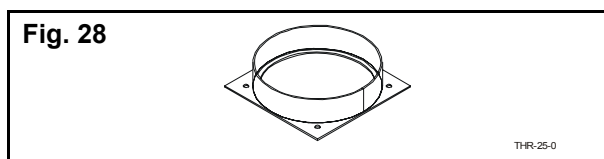

Reference	Ø int. (mm)
V00.15249	110

5.3.2.5 - Installation examples

Please refer to the guide when installing the kit.

Note:

- For lengths greater than 1 m (standard horizontal flue kit) use the extensions and bends supplied as an option.

$$L_{max} \leq 4 \text{ m}$$

5.3.2.5.1 - Straight horizontal balanced flue

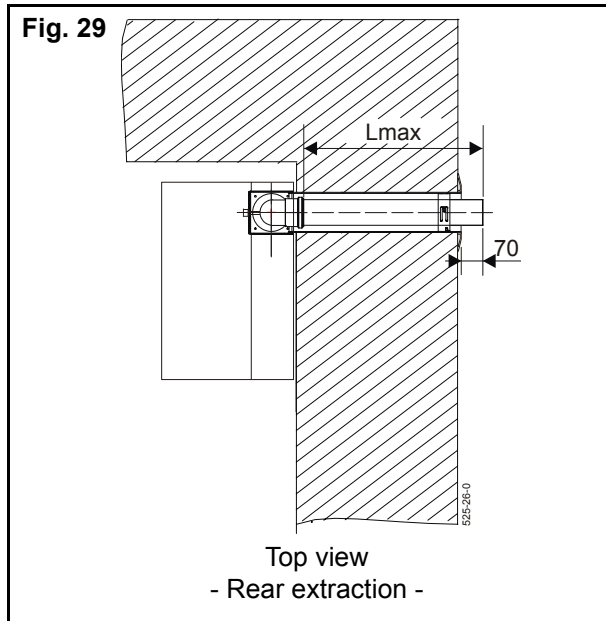

Accessory:

- 1 horizontal balanced flue kit - $l = 1 \text{ m}$.

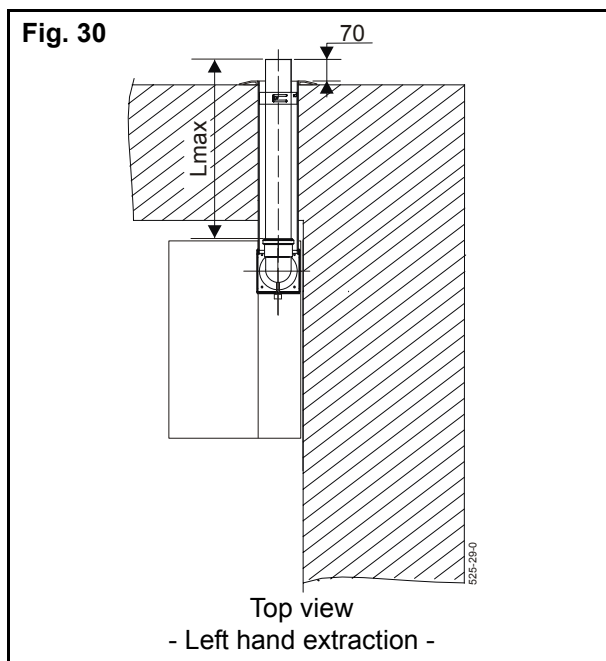

Accessory:

- 1 horizontal balanced flue kit - $l = 1 \text{ m}$.

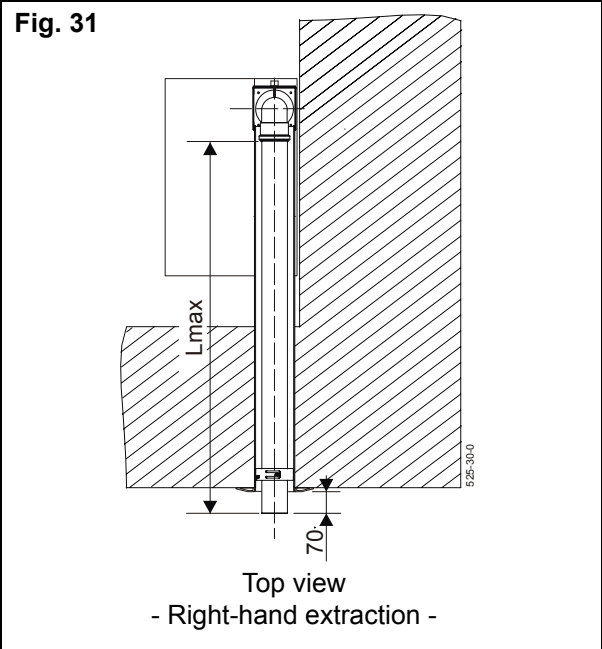

Accessory:

- 1 horizontal balanced flue kit - $l = 1 \text{ m}$.

5.3.2.5.2 - Flue with bend:

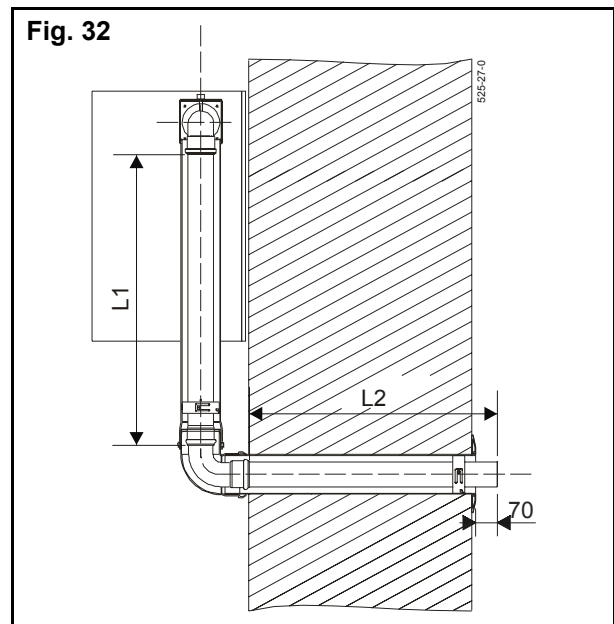

Accessories:

- 1 horizontal balanced flue kit - $l = 1 \text{ m}$.
- 1 concentric extension $\varnothing 75/110$ - $l = 1 \text{ m}$,
- 1 x 90° concentric bend $\varnothing 75/110$.

$$L_{max} = L1 + 1 \text{ m} + L2 \leq 4 \text{ m}$$

Note :

- Each 90° bend added reduces the total permitted length by 1m.

5.3.2.5.3 - Straight horizontal balanced flue with collar

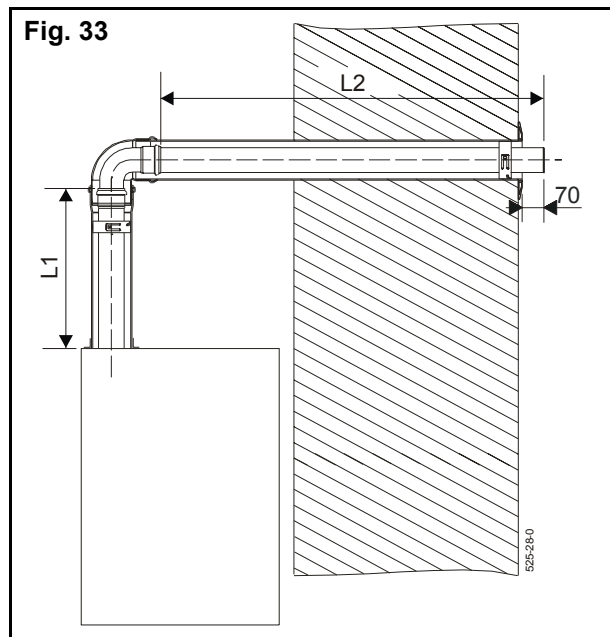

Accessories:

- 1 horizontal balanced flue kit - $l = 1 \text{ m}$,
- 1 adapting collar for the horizontal balanced flue,
- 1 concentric extension $\text{Ø } 75/110$ - $l = 1 \text{ m}$,
- 1 x 90° concentric bend $\text{Ø } 75/110$.

$$L_{\text{max}} = L1 + L2 \leq 4 \text{ m}$$

Note:

- The metal box and bend $\text{Ø } 75$ from the flue kit must not be used for this type of installation.
- The concentric extension can be cut to adapt to the required collar height.

5.3.3 - Extraction by vertical balanced flue (C33)

Besides the previously mentioned installation regulations pertaining to flues, the vertical flue terminal must allow a minimum distance of 30 cm between the roof level (sloping or flat) and the air intake zone.

The proximity of two terminals is also regulated: it is recommended that two adjoining terminals should be placed in the same horizontal plane. If this cannot be applied, the axis of the lower terminal must be at a distance of at least 0.60 m from the closest point of the air intake hole of the highest terminal.

Maximum length of vertical flue = 10 m

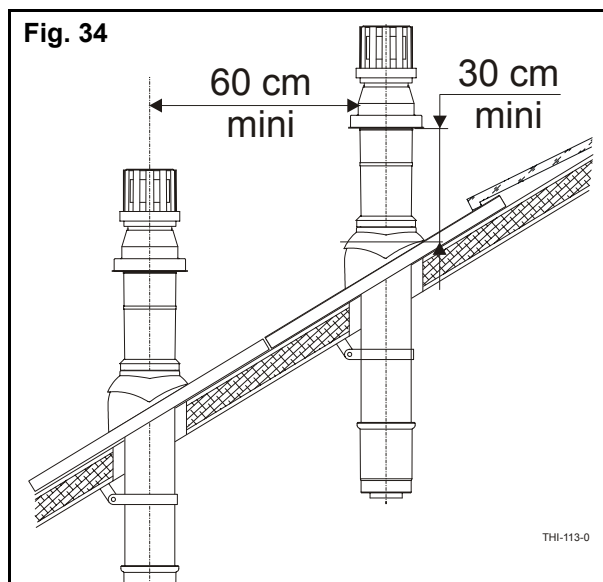

Evinox recommendations



Horizontal parts must be avoided to prevent any risk of condensate retention.

It is recommended to use 45° bends rather than 90° bends.

Use fastening collars for the vertical parts.

Position the terminal at least 1 metre from a vertical wall (end walls).

5.3.3.1 - PPtI/PVC concentric vertical terminal (option)

For sloping roofs.

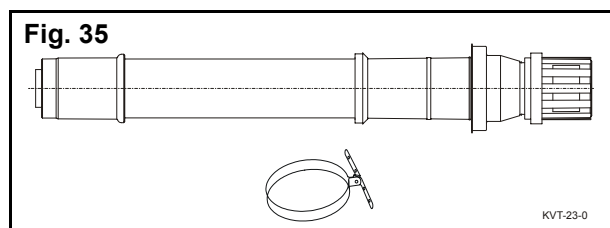

Reference	Colour	Length (*) mm	∅ int. mm	∅ ext. mm
N40.33615	Tile	1130	80	125
N40.33714	Black	1130	80	125

(*) Useful length under sleeve tile - l = 0.63 m

5.3.3.2 - Sleeve tile with adaptive coupling (option)

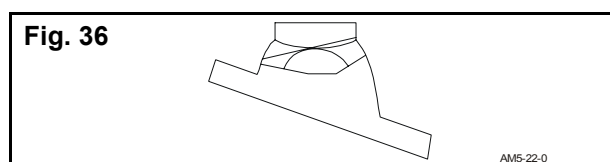

Reference	Slope	Type of covering	Colour
N40.12165	25 ° - 45 °	Tile*	Tile
N40.12166	35 ° - 55 °	Tile*	Tile
N40.12167	35 ° - 55 °	Slate - Shingle	Black

*Suitable for all types of tiles, for flat tiles < 8 mm use the Slate model

If accessories of any other brand are used, our guarantee of watertightness will be automatically void

5.3.3.3 - PPtI/PVC concentric extensions (option)

Joint fitting.

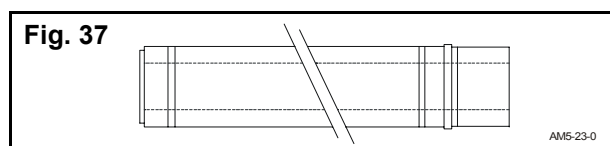

Reference	Length mm	∅ int. mm	∅ ext. mm
N40.28397	500	80	125
N40.28398	1000	80	125

(*) Useful length after assembly - l = 0.45 m or 0.95 m

5.3.3.4 - PPtI/PVC concentric bends (option)

Joint fitting.

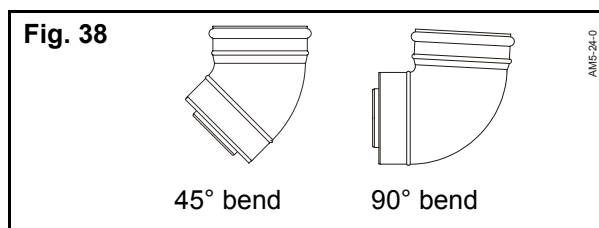

Reference	Type of bend	∅ int. mm	∅ ext. mm
N40.28395	45°	80	125
N40.28396	90°	80	125

Each 45° bend added reduces the total permitted length by 0.5m.

Each 90° bend added reduces the total permitted length by 1m.

5.3.3.5 - Polypropylene roof plate (option)

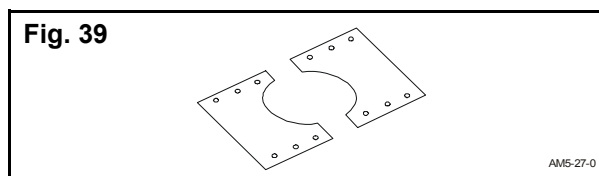

Reference	Colour
A90.12172	noir

5.3.3.6 - Fastening collar (option)

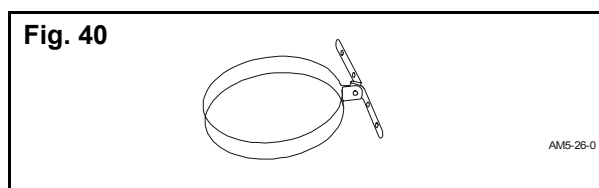

Reference	Quantity	∅ mm
B00.29727	3	125

These collars are essential to fix the vertically positioned extensions so that the boiler outlet does not bear the weight of the conduits.

5.3.3.7 - Adapting collar for the vertical balanced flue

See assembly instructions for the part.

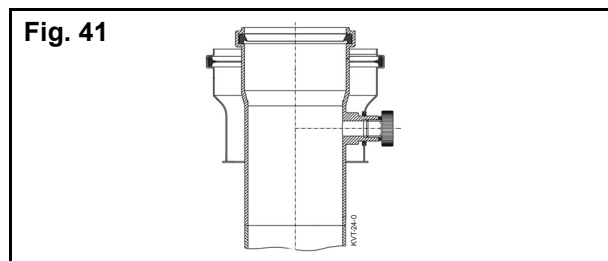

Reference	O10.33702
------------------	-----------

5.3.3.8 - Installation examples

5.3.3.8.1 - Straight configuration

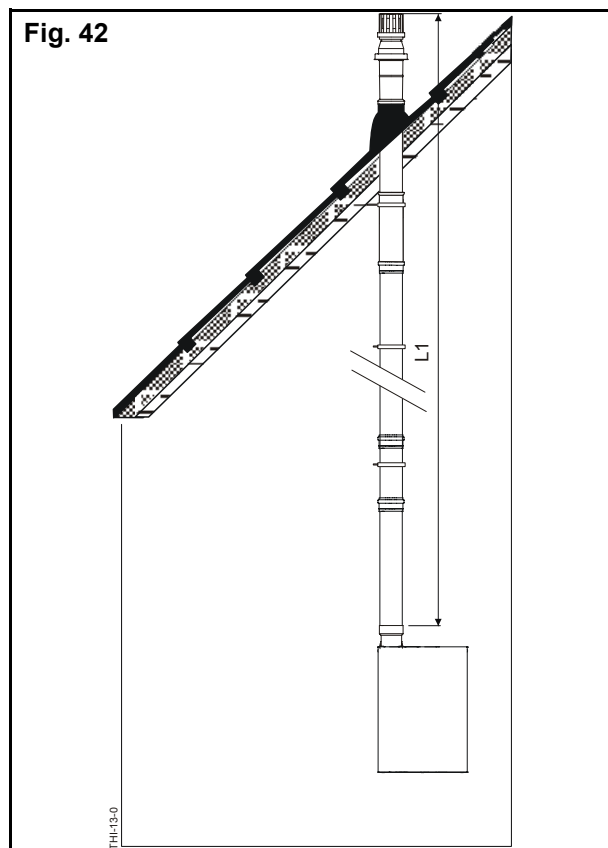

Accessories:

- Vertical balanced flue adapting collars,
- Concentric extensions Ø 80/125,
- 1 concentric vertical terminal Ø 80/125,
- 1 vertical terminal fastening collar (delivered with vertical terminal),
- 1 sleeve tile with adaptive coupling depending on the type of roofing and roof slope,
- 1 roof plate,
- 3 fastening collars Ø 125,

$L_{max} = L1 \leq 10 \text{ m}$

5.3.3.8.2 - Configuration with bends

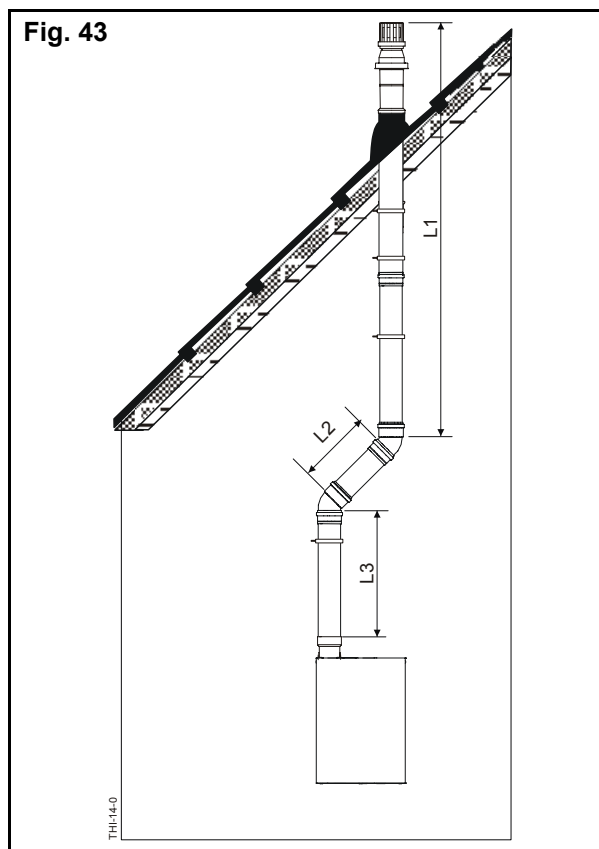

Accessories:

- Vertical balanced flue adapting collars,
- 3 concentric extensions Ø 80/125,
- 2 x 45° concentric bends Ø 80/125
- 1 concentric vertical terminal Ø 80/125,
- 1 vertical terminal fastening collar (delivered with vertical terminal),
- 1 sleeve tile with adaptive coupling depending on the type of roofing and roof slope,
- 1 roof plate,
- 3 fastening collars Ø 125,

$L_{max} = L1 + 0,5 \text{ m} + L2 + 0,5 \text{ m} + L3 \leq 10 \text{ m}$
--

Note:

- Each 45° bend added reduces the total permitted length by 0.5m.

6 - HYDRAULIC CONNECTION

6.1 - Evinox recommendations



When the boiler is assembled on an old installation, make sure that the installation is rinsed with fresh water, so as to clear any sediment stagnating in areas where the flow is slow. (Decantation should be provided).

Note: To validate the warranty one of our dirt separators must be fitted in accordance with our instructions to protect the boiler from any possible system debris when being installed to any system, new or old.

To prevent circulation noises in an installation featuring temperature controls, the following is recommended:

- Do not fit all the radiators with temperature controls,
- Fit a differential valve,
- Use an automatic speed variation pump.

In accordance with the decree of the Ministry of Health for the protection of the drinking water supply, the filling system must be fitted with a disconnecter of type CB (non-controllable pressure zone).

When required by Building control local byelaws, a thermostat mixing tap must be provided on the domestic hot water supply so as to limit the temperature at the tap connection (50°C).

Never position the isolation valve between the safety control box and the hot water tank (THI C + DHW production system or THI M75).

6.2 - Accessories to connect, install or adjust

- Bleed:

The bleed of the circulating pump features a flexible tube that can be connected to the outlet (condensate extraction funnel).

- Safety control box (for hot water production models):

The safety control box must be installed at a low point (0.25 m from the floor) to allow the domestic hot water tank to be emptied by siphoning. Otherwise provide a connection weld for a valve at a low point.

To prevent a rapid drop in pressure in the tank when hot water is being drawn, thus prematurely ageing the seals and the domestic hot water system itself, please ensure the following:

- properly size the cold water inlet tube to a diameter at least equal to or greater than the diameter of the hot water distribution,
- do not create large pressure losses on the cold water inlet by installing different accessories (various valves, etc.).

It is normal that the domestic hot water safety box lets a little water escape when heating the hot water tank.

However, to prevent these water flows from the safety box and if the cold water pressure exceeds 4 bars, it is advisable to:

- fit a pressure reducing valve on the cold water inlet.
- fit a d.h.w. expansion vessel at the cold water inlet between the safety box and the tank (refer to the instructions of the d.h.w. vessel for its size and the initial pressure according to the volume of the tank and the domestic cold water pressure).

- Isolating valve:

It is recommended to place isolation valves on the installation's flow-returns in order to allow possible servicing on the boiler without having to drain the installation.

- Safety valve:

This must be connected to the used water drain via a siphon funnel.

- Condensate outlet:

The condensate outlet must be connected to an accessible siphon.

- Expansion vessel:

If the installation capacity is over 100 litres, an extra expansion vessel to the boiler expansion vessel will be added.

The correct operation of the boiler requires an installation pressure of at least 1 bar.

If the installation is a renovation and uses an open vessel, this must be removed and replaced with a closed vessel to seal the circuit.

The vessel should be able to support an expansion of 6% of the total water capacity of the heating circuits. But it is important to note, in order to guarantee this expansion, that the useful capacity of a vessel does not equal its actual capacity.

Example:

- Installation: 100 litres
- Domestic hot water tank: 5 litres
- Boiler: 2,5 litres
- Total water capacity: 107,5 litres

Conditions: Using a vessel pre-loaded to 1 bar (under floor boiler = ground floor heating + 1 floor), heating safety valve calibrated at 3 bars, installation filled cold at 1 bar.

- Vessel efficiency calculation (R):

$$R = \frac{(\text{Safety Pressure} - \text{Filling pressure})}{\text{Safety Pressure}}$$

$$R = \frac{(3 + 1) - (1 + 1)}{(3 + 1)} = 0,5$$

+ 1) = the transformation of relative pressures into absolute pressures

- Calculation of the useful capacity of the vessel (Cu):

$$Cu = \text{total volume} \times \text{expansion}$$

$$Cu = 107,5 \times 0,06 = 6,45 \text{ dm}^3$$

- Calculation of the real capacity of the vessel (Cr):

$$Cr = \frac{Cu}{R}$$

$$Cr = \frac{6,45}{0,5} = 12,9 \text{ litres}$$

6.3 - Under-floor heating recommendations

(Refer to the section 1 - page 43 - chapter V - SETTINGS OF THE INSTALLATION TYPES - INSTALLATION MANUAL).

When the boiler directly supplies an under floor heating system and this system is also used to produce domestic hot water (THI..C + BS / THI..M75), make sure that the installation has sufficient extra capacity to utilise the excess heat produced at the end of the domestic hot water heating cycle. This capacity should be in the region of 10 litres.

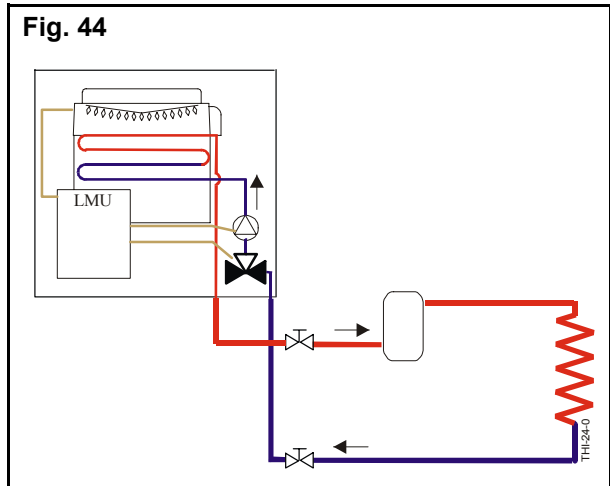

6.4 - Heat exchanger flow rate

Whenever the size of the installation is such that it absorbs the maximum power of the boiler, please ensure that there is the following minimum water flow in the exchanger.

Type	Flow
THI 0.9-9	0.39 m ³ /h
THI 2-17	0.75 m ³ /h
THI 5-25	1.03 m ³ /h

If the boiler directly feeds under-floor heating at low ΔT. the necessary flow may be higher. In this case, please take the ΔP of the boiler into account and if necessary install a header between the boiler and the installation.

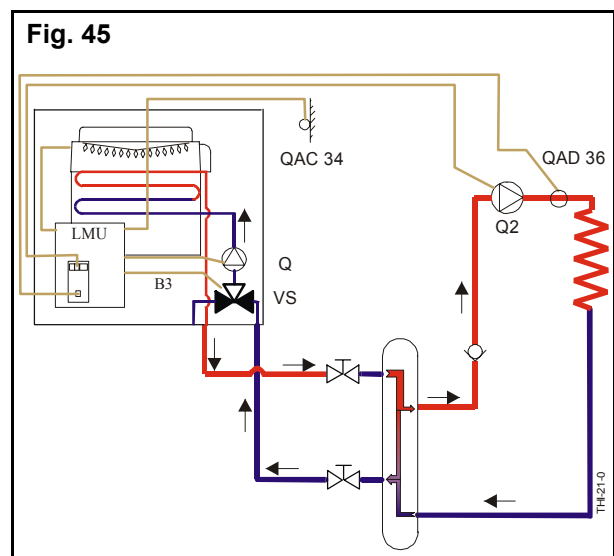

6.5 - Hydraulic connection for models THI 0.9-9 C /THI 2-17 C and THI 5-25 C

Fig. 46

- 1) Gas inlet
- 2) Gas cock
- 3) Boiler
- 4) Radiator
- 5) Heating flow isolation valve
- 6) Heating flow
- 7) Heating return isolation valve
- 8) Heating return
- 9) Cold water inlet
- 10) Filling valve
- 11) Removable filling loop
- 12) Isolation valve
- 13) Drain for condensates, valve, bleed
- 14) Removal towards drain
- 15) QAA73 room sensor (option)
- 16) Outside sensor QAC 34

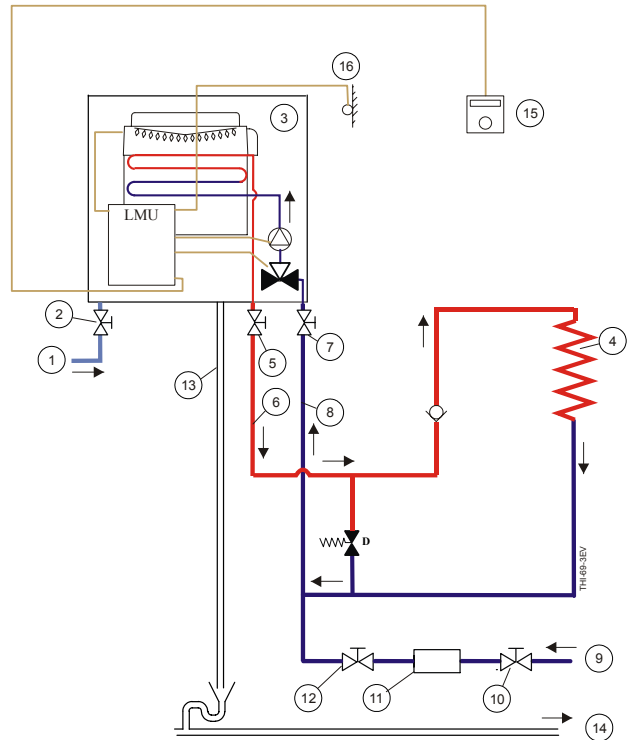

6.6 - Hydraulic connection for models THI C+ DHW production system of type BS

Fig. 47

- 1) Gas inlet
- 2) Gas cock
- 3) Boiler
- 4) Radiator
- 5) Heating flow isolation valve
- 6) Heating flow
- 7) Heating return isolation valve
- 8) Heating return
- 9) Cold water inlet
- 10) Filling valve
- 11) Removable filling loop
- 12) Isolation valve
- 13) Drain for condensates, valve, bleed
- 14) Removal towards drain
- 15) QAA73 room sensor (option)
- 16) Outside sensor QAC 34
- 17) DHW production system of type BS
- 18) Primary inlet
- 19) Primary outlet
- 20) Safety control box
- 21) DHW expansion vessel
- 22) Pressure reducer

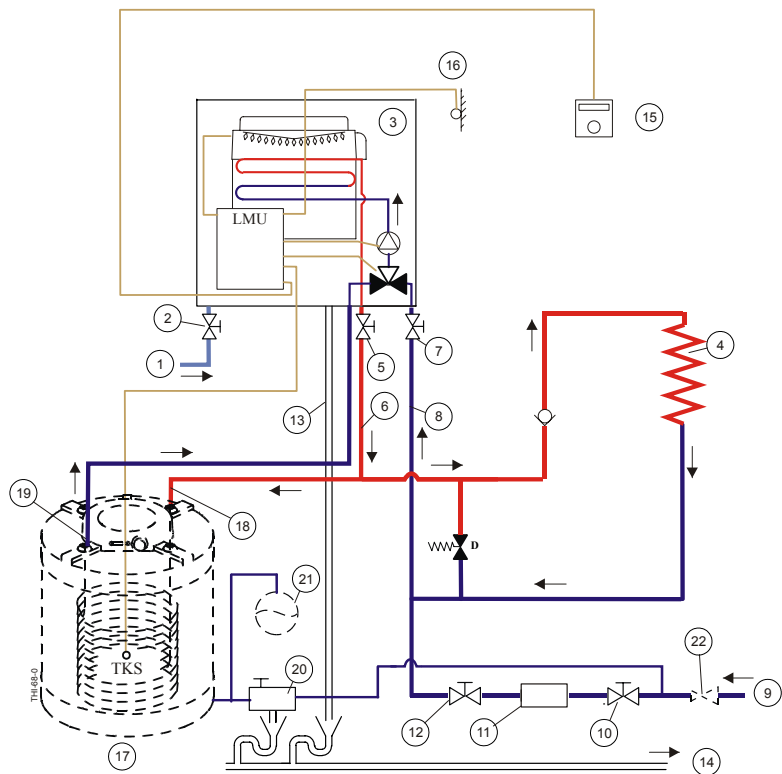

6.7 - Hydraulic connection for models **THI 5-25 M75 V**

Fig. 48

- 1) Gas inlet
- 2) Gas cock
- 3) Boiler
- 4) Radiator
- 5) Heating flow isolation valve
- 6) Heating flow
- 7) Heating return isolation valve
- 8) Heating return
- 9) Cold water inlet
- 10) Domestic cold water inlet
- 11) Removable filling loop
- 12) /
- 13) Drain for condensates, valve, bleed
- 14) Removal towards drain
- 15) QAA73 room sensor (option)
- 16) Outside sensor QAC 34
- 17) Domestic hot water flow
- 18) Safety control box
- 19) DHW expansion vessel
- 20) Pressure reducer

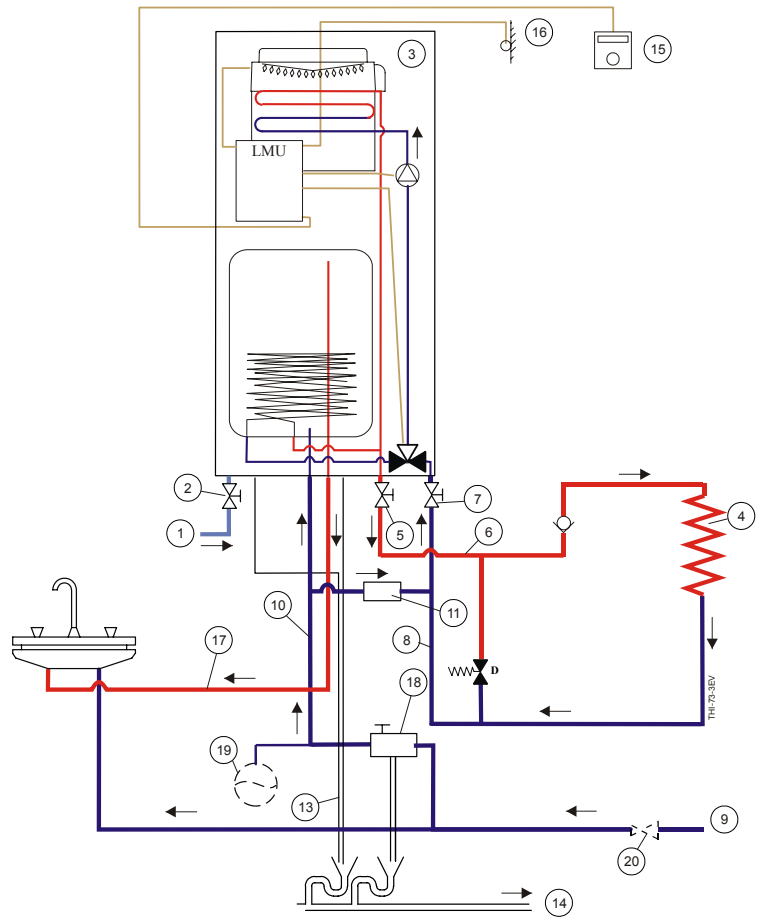

7 - GAS CONNECTION



The boiler is pre-set in the factory for natural gas. For operation on propane, see chapter II - GAS CONVERSION - page 10 - SERVICING MANUAL

- The inlet diameter of the boiler gas pipe is 1".
- In natural gas operational mode, a gas stopcock complying to gas regulations must be installed on the gas inlet close to the boiler and within easy access.
- For operation on propane (for the THI 5-25 models), the 37 mbar pressure-reducing valve-trigger used as a gas cock must also remain accessible.
- Make sure that the gas inlet connections are correctly tightened on the boiler.
- Only use connections and gaskets that are approved for gas installation use.
- The gas pipe should be flushed before putting the boiler into operation. This is to evacuate any particles created by welding or fitting connections.

- Never flush the gas pipe whilst the boiler is operational (Max Gas Pressure = 100 mbar).
- The gas pipe to the boiler should not cause load losses in excess of 1 mbar (10 mmCE).

Example: For natural gas type G20, 20 mbar for 10 metres of piping and 4 bends: minimum diameter 20/22.

7.1 - Connection of a gas safety solenoid

This may be compulsory for propane and depends on the local gas regulations.

The connection of a gas safety solenoid requires the "programmable clip-in with flow sensor" option.

8 - ELECTRICAL CONNECTION

- The electrical connection and all the equipment used to make this connection must be in conformity with the codes of practise in force (according to the installation standards),
- the premises must be suitable in terms of boiler protection IP 44 (model C₁₃ - C₃₃) - IP 24 (model - B₂₃),

8.1 - Mains connection

- Electrical connection of the boiler to the mains using the supply cable.
- Power supply: 230 V - 50 Hz (single phase),
- Respect the Live-Neutral polarities,
- Earth connection compulsory.

8.2 - Connection of the sensors to the LMU management unit

To connect the sensors to the X10 or X11 terminal of the LMU management please refer to the connection diagram on section 8.4 - page 42 - chapter IV - INSTALLATION - INSTALLATION MANUAL or to the sensor.



If a fault code is displayed when fitting the sensor to the LMU management unit please refer to chapter IV - OPERATING FAULTS - page 18 - SERVICING MANUAL.

8.3 - Under-floor heating safety

In compliance with the regulations, a safety system must be installed. This system must be separate from the temperature control, feature a manual reset, and must cut off the supply of heat and operate even when there is no current or motor fluid (according to the installation standards).

- Terminal X10-03: Under-floor heating safety connection (limiter) (item. 33, fig. 49 - page 42 - chapter IV - INSTALLATION - INSTALLATION MANUAL),
- Terminal X3-01: Under-floor heating safety connection (manual reset) (item. 34, fig. 49 - page 42 - chapter IV - INSTALLATION - INSTALLATION MANUAL).

8.4 - Wiring diagram

Fig. 49

- 31) Flow sensor QAD36 (relay clip-in)
 - 32) Communication bus (LPB clip-in)
 - 33) Under-floor heating safety connection (limiter)
 - 34) Under-floor heating connection (manual reset)
 - 35) ON/OFF switch
 - 36) Programmable output
- * Shunt to be removed for operation with room sensor QAA73 (20)
 ** Phase in idle position

- 23) Connection for clip-in AGU2.5xx (option)
- 24) Removable fuse
- 25) Q2 pump (2nd circuit clip-in)
- 26) Mixing valve motor (2nd circuit clip-in)
- 27) Flow sensor QAD36 (2nd circuit clip-in)
- 28) Q8 pump (relay clip-in)
- 29) Gas safety solenoid (relay clip-in)
- 30) Alarm (relay clip-in)

- 14) AN2 (boiler return sensor)
- 15) AN1 (boiler flow sensor)
- 16) AN5 (outside sensor)
- 17) AN3 (DHW1 sensor)
- 18) Programmable digital key (e.g. modem)
- 19) Room thermostat/clock*
- 20) Room sensor (QAA73)
- 21) Connection for clip-in OC1420 or clip-in AGU2.5xx (option)
- 22) Control module (MMI = AGU2.3xx)

- 1) Mains supply connection
- 2) Clip-in mains connection (option)
- 3) Fan motor 230 V~
- 4) Q (heating circulating pump)
- 5) Selector valve
- 6) Ionizing electrode
- 7) Gas unit 230 V~ / RAC
- 8) Ignition transformer 230 V~
- 9) Fan PWM signal
- 10) DHW flow detector
- 11) PWM pump
- 12) AN6 (pressure sensor)
- 13) AN4 (Flue gas sensor)

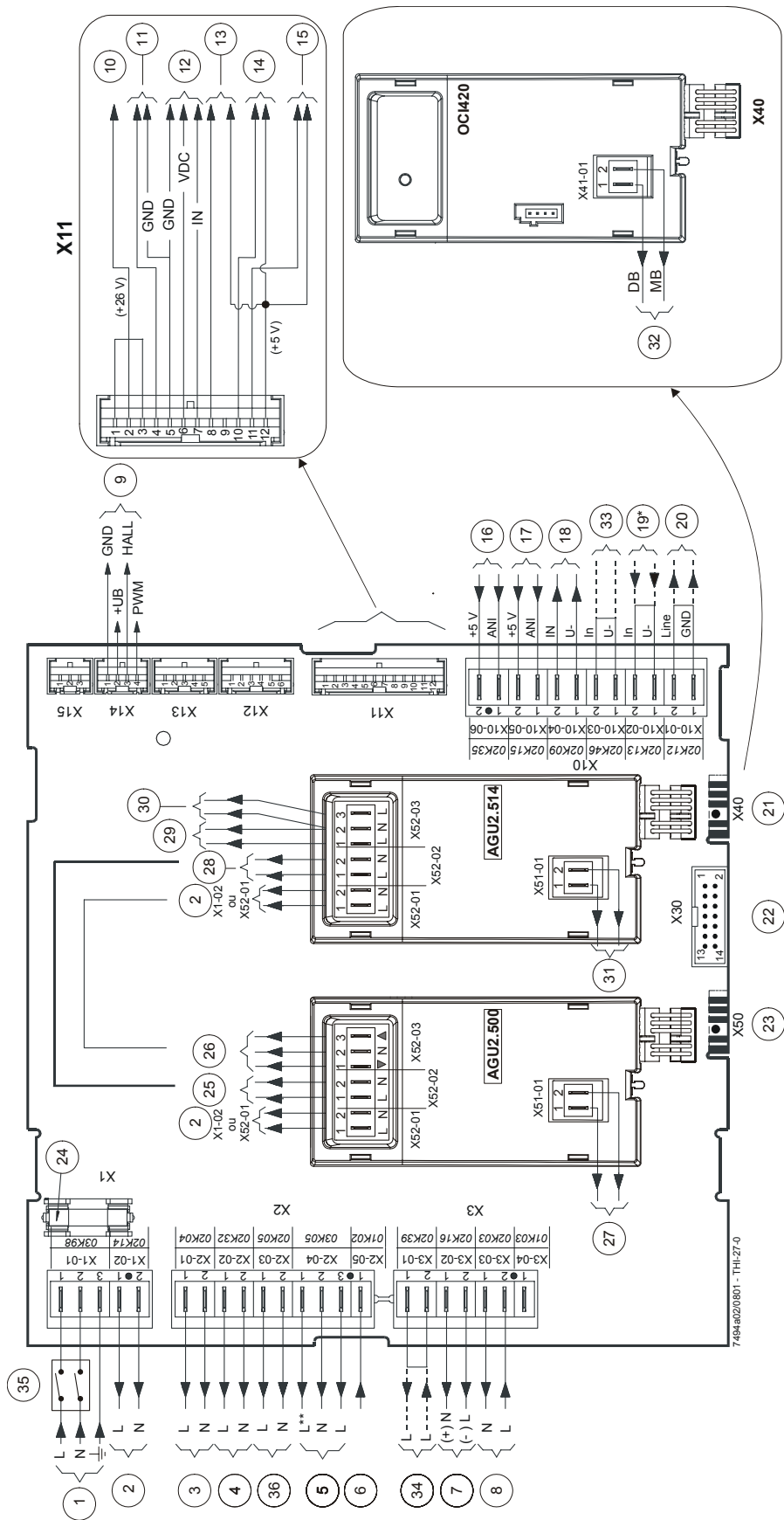

V - SETTINGS OF THE INSTALLATION TYPES



The outside sensor is necessary and must be connected to the LMU (terminal X10-06).

The QAA 73 room sensor is required to access the settings and to adjust them.

Refer to the QAA 73 room sensor instructions (installation precautions).



Only the radiator of the room in which the QAA 73 room sensor is installed must not be fitted with a thermostatically controlled valve.



The boiler's standard setup is used for the connection of:

- a Radiator circuit (CC1) controlled by the boiler's LMU,
- an Under-floor heating circuit (CC2) by using the clip-in 2nd circuit kit (Refer to table fig. 51 - page 44 - chapter V - SETTINGS OF THE INSTALLATION TYPES - INSTALLATION MANUAL).



The room influence on the under-floor heating circuit must be disabled if the room sensor is installed in this room (line 75 set to "none").

1 - SINGLE CIRCUIT

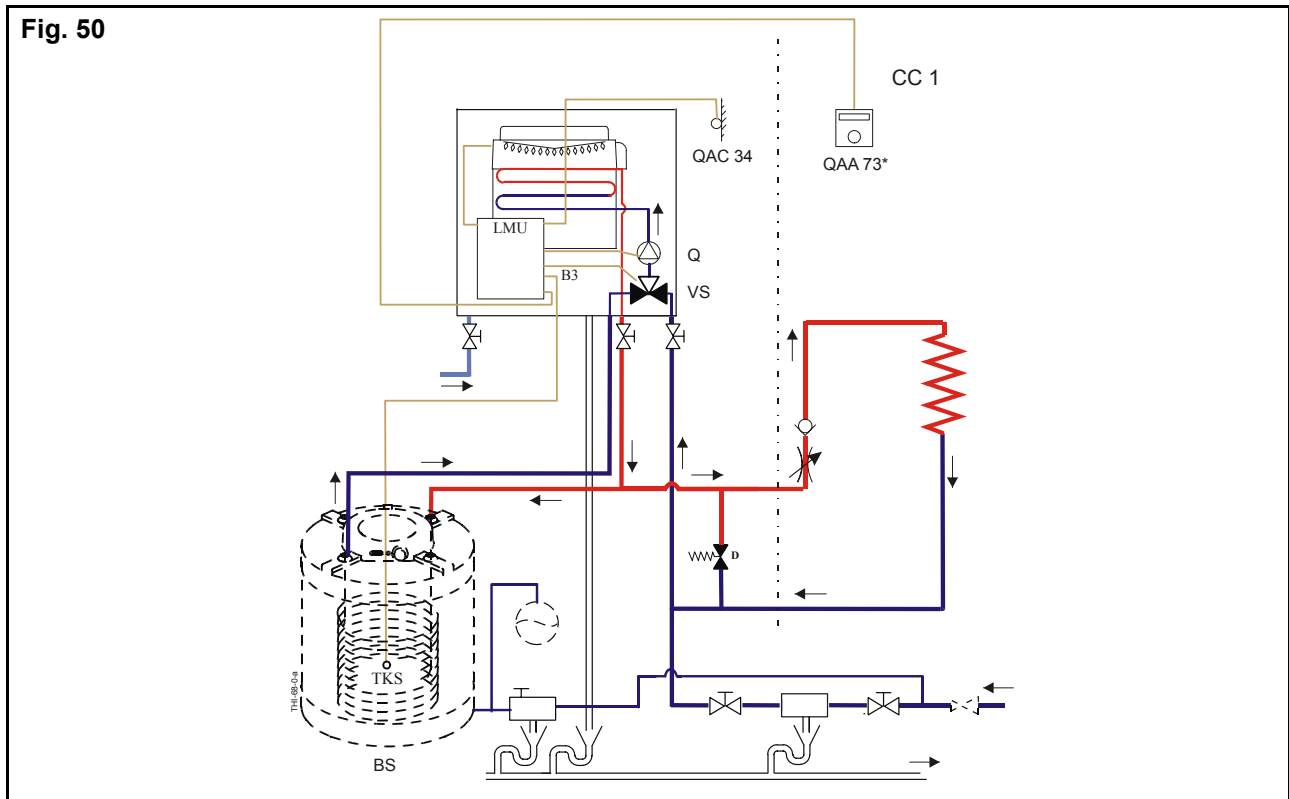

Function	FACTORY SETTINGS QAA73		QAA 73 SETTINGS TO CHANGE	
	Radiator circuit (CC1)		Under-floor heating circuit (CC1)	
	line QAA73	Value	line QAA73	Value
Slope	70	15	70	8
Tmax	72	80°C	72	50°C
Parallel shift	73	0	73	0
Room influence	75	CC1	75	none

Note:

- In the case of a single circuit (CC1) either a radiator circuit or an under floor heating circuit
- However if the boiler directly supplies an under floor heating circuit:
 - The QAA 73 settings need changing in accordance with the table above.

- For recommendations refer to section 6.3 - page 38 - chapter IV - INSTALLATION - INSTALLATION MANUAL.

Necessary Evinox accessories

Accessories list	Reference
A room temperature sensor (QAA 73)	REG 73

2 - DOUBLE CIRCUIT



The double circuit function is not compatible with the modulator pump option.

If a double circuit installation is to be used with a boiler fitted with a modulator pump, it is necessary to change KonfigRg 7 parameter by the intermediary of the QAA73 room sensor (refer table fig. 51 - page 44 -

chapter V - SETTINGS OF THE INSTALLATION TYPES - INSTALLATION MANUAL).

The radiator circuit must be fitted with thermostatically controlled valves to fine-tune the control for each room. Heating circuit 1 (CC1) must operate at a temperature greater than or equal to the heating circuit 2 (CC2).

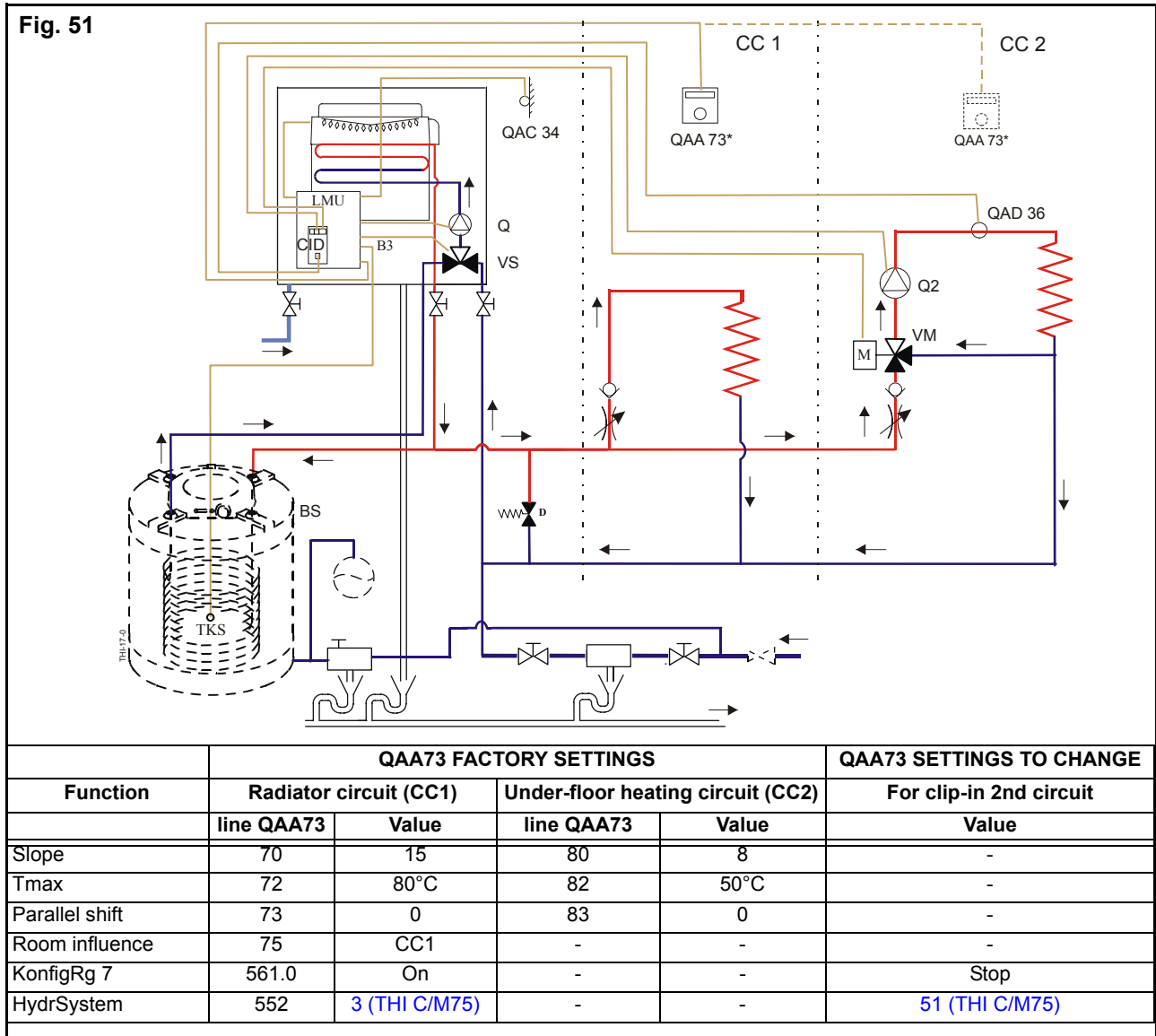

Nota :

- If the 2nd circuit (CC2) is another heating circuit, the values of the slope (8) and the temperature (50°C) must be modified via the QAA73 room sensor and brought to the standard values (slope: 15 - T max: 80°C) (refer to table above).

Necessary Evinox accessories

Accessories list	References	
A second circuit clip-in kit (CID)	REG 125	W07.30833
A mixing valve motor (M)		
A 3 ways mixing valve (VM)		
A room temperature sensor (QAA 73)	REG73	REG 73
A 2 nd circuit pump (Q2)	not supplied	

- Refer to their respective fitting instructions

2.1 - Without room sensor

The flow temperature of each circuit is defined by the heating curve for that circuit.

This temperature is corrected by using the boiler heating potentiometer (setting from 17°C to 23°C).



Correction of the room temperature using the heating potentiometer acts on both heating circuits simultaneously.

2.2 - With room sensor

Only one QAA73 room sensor can be connected to the LMU. It can control one or two circuits.

Maximum distance between the boiler and the QAA 73 = 50m.

The QAA73 room sensor is configured in the factory on the CC1 radiator circuit.

The sensor defines the flow settings required as well as the domestic hot water temperature and sends them to the boiler control on the basis of the outside temperature, room temperature and various other parameters.

The heating and domestic hot water potentiometers are then disabled when the sensor is connected.

VI - APPROVALS

1 - DECLARATION OF CONFORMITY

Appendix II article 3.1 of 90/396/EEC directive
Appendix IV module D of 92/42/EEC directive

SERIES : **THI RANGE**

MANUFACTURER : **GEMINOX SAS**
16 rue des Ecoles
29410 SAINT THEGONNEC

PRODUCT CATEGORY : **GAS CONDENSING WALL-HUNG BOILER RANGE ONLY HEATING OR WITH DHW PRODUCTION**

NOTIFIED BODY : **0085/DVGW**
Josef-Wirmerstr. 1-3
D-53123 BONN

TYPE/NO. EXAMINATION : **THR / THRi / THI 5-25 : CE0085AQ0543**
THR / THRi / THI 0.9-9/2-17 : CE0085AT0244

TEST LABORATORY : **GWI**
HAFENSTRASSE 101
45356 ESSEN

EC DIRECTIVES : 90/396 EEC, 92/42 EEC, 73/23 EEC, 89/336 EEC
97/23 EEC article 3.3

BASIS OF EXAMINATION : EN 437, EN 483, EN 677,
EN 60335.1, EN 55014, EN55104

SURVEILLANCE PROCEDURE : **Manufacturing quality assurance**

DECLARATION : **The a.m. products are manufactured true to the a.m. directives as well as to the approved models. The manufacturing is examined true to the a.m. surveillance procedure. The THRi boilers comply with the requirements relating to the condensing heating boilers.**

Saint-Thégonnec February 2003 :



VII - EVINOX WARRANTY

All THI boilers come from the manufacturer, Geminox France, with a 5-year warranty on the heat exchanger and 5 years on the burner. All other parts are covered by a 2-year parts warranty. All replacement parts are covered by a further 1-year parts warranty. The manufacturer's warranty covers only the parts, labour costs are excluded.

In addition to the factory warranty, the distributor Evinox, also provides a further 5-year warranty on the heat exchanger and a further 3-year warranty on the LMU. Labour warranty applies for the 1st year only. To validate the warranty, the boiler must be commissioned by Evinox.

The boiler should be fired and the gas rate checked prior to final commissioning by our engineers. Operating the boiler outside the commissioning parameters will invalidate the warranty. If the boiler is commissioned and regularly serviced by Evinox the labour warranty will be validated. Failure to have the boiler commissioned and regularly serviced by Evinox or a CORGI approved boiler service engineer will invalidate any warranty claims.

It is a condition of the warranty that the boiler is serviced annually within 4 weeks of the due date, this being calculated from the time of sale.

The log book within the boiler should be filled in at the time of commissioning and servicing and should be supported by a copy of the engineer's Service Report and print out of combustion settings to validate the warranty. Failure to complete this logbook correctly will invalidate the warranty.

Failure to comply with the relevant installation requirements of the Gas Safety Regulations, Building Regulations, Local Water Bylaws and Building Standards will invalidate any warranty claim. If a gas boiler is installed by a non-CORGI-registered installer the warranty will be invalid.

All boilers to be fitted with isolation valves for servicing and warranty work. Warranty calls that include draining the system will be chargeable if isolation valves have not been fitted.

It is imperative that the level of Bionibal corrosion protector within the boiler is kept within Evinox stipulations at all times, which is 1% for radiators and 2% for UFH. Special attention should be given to ensure that, after any decoration or building works where radiators might be removed, the system is replenished with Bionibal. Non-use of our inhibitor and use of another product will invalidate the warranty.

We will register the warranty when we commission the boiler.

Any warranty claims that are a result of user error, poor installation or lack of servicing will be chargeable. Please note that all replacement parts provided under warranty are subject to factory inspection to determine cause of failure. Replacement parts are chargeable until passed as faulty by Evinox, when a credit will be provided. Any parts that have failed as a result of poor servicing or misuse will not be covered by our warranty.

Any modifications to the appliance will invalidate the warranty.

Your Evinox appliance is one of the most reliable and technically advanced products available. However, it is imperative that it is installed correctly, commissioned and serviced in accordance with Evinox installation and servicing manuals to ensure long life, reliability and fuel savings.

Evinox

H E A T I N G

Evinox - Blenheim House - 1 Blenheim Road - Surrey KT19 9AP T : +44 (0)1372 722277 F : +44 (0)1372 744477
E : sales@evinox.co.uk - technical@evinox.co.uk
www.evinox.co.uk
Company number 4404137

With a view to constantly improving their products, GEMINOX reserves the right to modify the characteristics of their equipment without notice. - UK 2008 / 07